

**SOI Asia Network**

**Document**

# Introduction to SOI-Asia Network

August 16, 2006

## 1 Introduction

A satellite covers a wide area on the earth and can broadcast data beyond the limitations of geographical boundaries. Satellite links are effective infrastructure to provide Internet connectivity in the areas where terrestrial data links or additional bandwidth for an existing data link is hardly available.

SOI-Asia network is the network infrastructure which supports the whole SOI-Asia activities. SOI-Asia system has specific requirements and restrictions in terms of bandwidth, geographically distributed partners, network topology, resources and applications. Therefore, SOI-Asia network is specially designed to meet all those requirements and restrictions.

## 2 SOI-Asia Network Overview

### 2.1 Topology

SOI-Asia network uses a satellite link as a Uni-Directional Link (UDL) like the figure 1 because of following reasons.

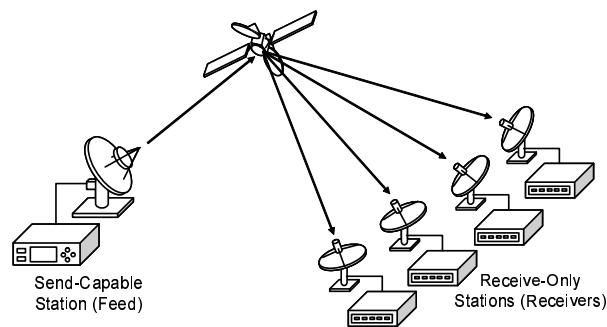

Figure 1: Satellite Uni-Directional Link

- Satellite uni-directional link can broadcast data over satellite to many countries, which makes it easier to share the information among partners.
- Receive-only earth stations are cheaper than transmit-capable earth stations, thus making the environment easier to build.

- In most countries, we do not need transmission licenses for receive-only earth stations, while it is very difficult to obtain one for transmit-capable earth stations.
- We do not need radio specialists in receive-only sites.

Figure 2 shows the outline of SOI-Asia network topology. The satellite link in the figure is the uni-directional communication media from Japan to partners.

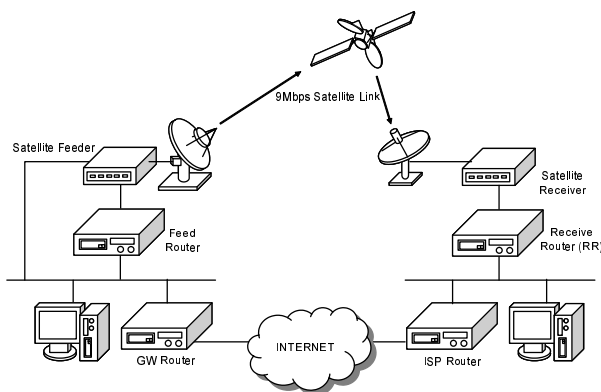

Figure 2: SOI-Asia Network Topology

The network in the right side is SFC which has the transmit-capable earth station for SOI-Asia satellite link and works as the upstream of each partner site. On the other hand, the network in the right side is the receive-only site established in each partner organization.

## 2.2 Receive-Only Site in SOI-Asia Partner

The figure 3 shows the network topology of a receive-only site.

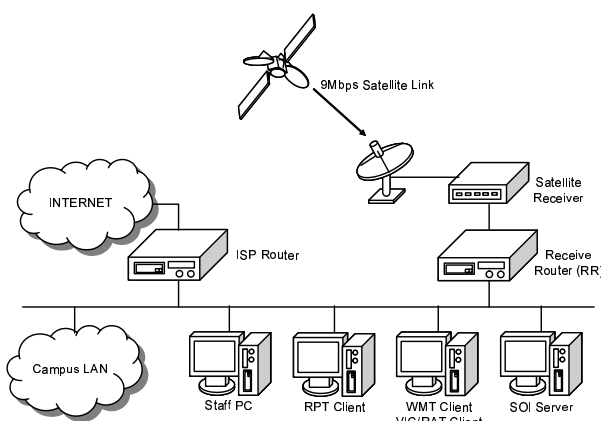

Figure 3: Network Topology of Receive-Only Site

The satellite link in the figure 2 is the communication media from Japan to partners. The network in the right side is SFC which has the transmit-capable earth station for SOI-Asia satellite link and works as the upstream of each partner site. The receive-only site has a receive-only earth station to receive data from the satellite link. SOI-Asia assigns a global IPv4/v6 address space to each partner. The global IPv4 addresses could be assigned to machines which have important roles in SOI-Asia activities: Receive Router, SOI Server, WMT client, RTP client, VIC/RAT or Polycom and staff machine.

Figure 4 shows the logical subnets in the receive-only site. Besides the global IP address assigned to SOI-Asia, each partner site must have another network to access to the Internet, to be able to send traffic back to Japan. It can be a local ISP, dialup or the partner's campus network in the case that campus has another way out to Internet. In case of any additional hosts, they will be placed in a private network using private addresses, noted as the campus LAN. Therefore, several logical subnets are layed on a single link in each receive-only site.

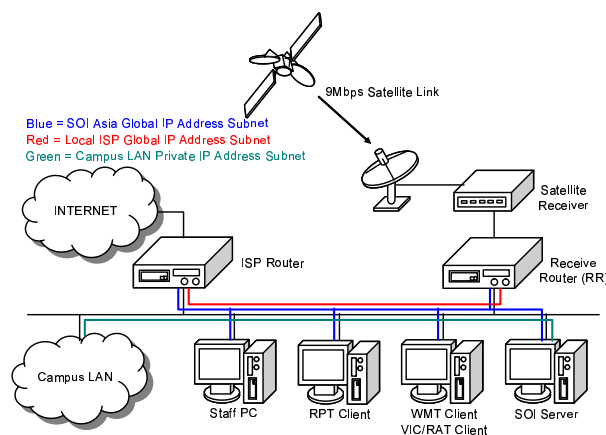

Figure 4: Logical Subnets on Receive-Only Site

### 3 Uni-directional Link Routing (UDLR)

#### 3.1 Background of UDLR

In the Internet, data links are generally categorized into 3 types: "Point-to-Point", "Broadcast-Capable Multiple Access" and "Non-Broadcast Multiple Access". However, a uni-directional link does not mach any of these 3 types. Therefore, in this scenario of uni-directional links, because most protocols and applications of the Internet assume that the data link is compliant to these 3 types of links, those applications do not work correctly. Many routing algorithms, for examples, OSPF, IGMP, PIM, DVMRP, requires two-way broadcasting ability on the link.

#### 3.2 Node Definition in UDLR

In order to utilize the satellite UDL, SOI-Asia employs UDLR, a set of technologies which emulate Broadcast-Capable Multiple Access link on the unidirectional link. In

the UDLR specification, several types of nodes are defined. In this document, we focus on "Send-only Feed" and "Receiver" to explain UDLR simply. Note that SOI-Asia network is composed of these two types of nodes.

**Send-only Feed** A router that has send-only connectivity to a UDL.

**Receiver** A router or a host that has receive-only connectivity to a UDL.

### 3.3 UDLR Technologies

UDLR is composed of three technologies: Link Layer Tunneling Mechanism, Broadcast Emulation and Dynamic Tunnel Configuration Protocol.

#### 3.3.1 Link-Layer Tunneling Mechanism (LLTM)

LLTM is a technology that delivers a data link frame from Receiver to Send-only Feed via the other Internet infrastructure by encapsulating the data link frame in the GRE (Global Routing Encapsulation) header. Because LLTM deliver a data link frame with keeping its same shape when it was sent from the I/F of the Receiver on the UDL, Send-only Feed treats that data link frame as if it was directly received from UDL. Figure 5 shows how LLTM works on Send-only Feed and Receiver.

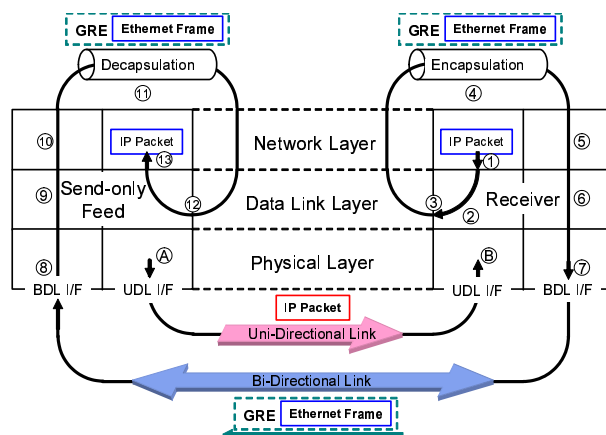

Figure 5: Link Layer Tunneling Mechanism

#### (From Receiver to Send-only Feed)

- 1 Receiver sends an IP packet to Send-only Feed on satellite UDL. Because Send-only Feed is visible on UDL from Receiver, Receiver is about sending the packet to Send-only Feed on UDL.
- 2 For the Ethernet header which is attached to the originated IP packet, the destination MAC address is that of UDL I/F of FEED and the source MAC address is that of UDL I/F Receiver.
- 3 Because LLTM knows that Receiver can't transmit the data link frame to UDL, LLTM captures the data link frame before it is passed to UDL I/F. Then, LLTM send the data link frame to the encapsulation functionality of Receiver.

- 4 LLTM encapsulates the captured data link frame in the GRE header. The encapsulated data link frame is passed to the network layer of BDL side stack to send it via the Internet.
- 5 - 7 The IP header is attached to the GRE encapsulated payload and it is transmitted from BDL I/F of Receiver to the Internet.
- 8 - 10 The GRE-encapsulated data link frame is reaching BDL I/F of Send-only Feed through the Internet and passed to the upper layers.
- 11 On Send-only Feed, LLTM detaches GRE header to decapsulate the original data link frame from Receiver. Then, LLTM passes it to the data link layer of UDL side stack on Send-only Feed.
- 12 - 13 Send-only Feed processes the data link frame as if it were incoming from UDL I/F and pass it to the upper layers. At last, the original IP packet reaches FEED on satellite UDL as if it were directly delivered from Receiver to Send-only Feed.

**(From Send-only Feed to Receiver)**

**A - B** Send-only Feed can just send an IP packet to Receiver via UDL.

### 3.3.2 Broadcast Emulation

Broadcast Emulation is the technology that Send-only Feed transmits a received data link frame to the UDL. Then, the data link frame could be shared among other Receivers like Ethernet. Broadcast Emulation emulates Broadcast-Capable Multiple Access Link on the UDL.

Broadcast Emulation makes Send-only Feed transmit a data link frame if it is destined to Receiver's MAC address, a broadcast address or a multicast address. Here Receiver can send a packet to other Receiver by way of Send-only Feed, which realizes bidirectional communication between Receivers on UDL.

Broadcast emulation is essential to successfully complete ARP or other infrastructure technologies of the Internet. Figure 6 shows how Broadcast Emulation works taking ARP as an example.

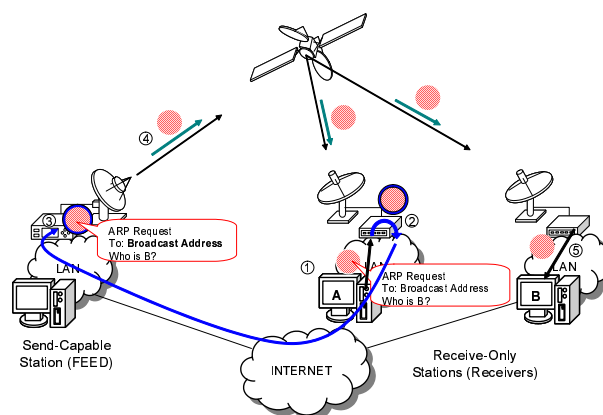

Figure 6: ARP with Broadcast Emulation

- 1 Host A wants to send an IP packet to Host B. Host A sends an ARP request to know what the MAC address of Host B is.
- 2 The ARP request is encapsulated by LLTM on Receiver and reaches FEED through the Internet.
- 3 Now Feed decapsulates the GRE-encapsulated data link frame, and the ARP request appears, whose MAC address is destined to the UDL subnet's broadcast address.
- 4 Broadcast Emulation forwards the decapsulated data link frame to the satellite UDL, if its destination MAC address is that for multicast or broadcast. Then the ARP request is forwarded to the satellite UDL.
- 5 Host B receives the ARP request from Host A, and host B can send an ARP reply successfully.

### 3.3.3 Dynamic Tunnel Configuration Protocol (DTCP)

Dynamic Tunnel Configuration Protocol is the protocol that the Send-only Feed periodically advertise their IP address as the end-point of LLTM over UDL. Listening to the advertisement from Send-only Feed, Receivers know where to send GRE encapsulated packets.

DTCP Hello is a packet that delivers the IP address of the tunnel end-point. Because Receivers rely on DTCP for knowing the tunnel end-point, if that packet does not come from UDL, Receivers can not activate LLTM any more.

## 3.4 UDLR in SOI-Asia Network

In the UDLR specification, Send-only Feed is dedined as a router. And Receiver is defined as a router or a host. But, in the SOI-Asia network, the UDLR functionality is separated from a router or a host for both Send-only Feed and Receiver.

**Satellite Feed** A host that has send-only connectivity to a UDL. It provides the functionality of Send-only Feed but does not have any routing capability.

**Satellite Receiver** A host that has receive-only connectivity to a UDL. It provides the functionality of Receiver but does not have any routing capability.

**Feed Router** A router that is connected to Feed. It does not have the UDLR functionality and performs as a generic router.

**Receive Router** A router that is connected to Receiver It does not have the UDLR functionality and performs as a generic router.

Figure 7 shows how UDLR works in SOI-Asia network. Here Source is a host in a receive-only site and Destination is a host in Japan site, which is the upstream network of the receive-only site.

- 1 Source sends an IP packet to Receive Router, which is the default router of Source. Receive Router forwards the IP packet to Feed Router.
- 2 Satellite Receiver captures an Ethernet frame transmitted by Receive Router and encapsulate that frame in GRE header and IP header in which the source IP address is that of Satellite Receiver and the destination is LAN I/F of Satellite Feed.

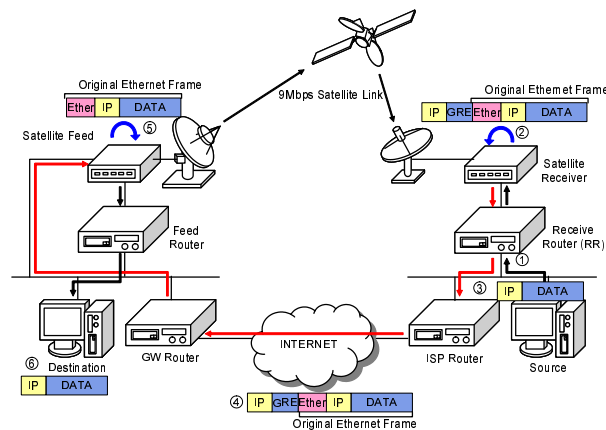

Figure 7: UDLR in SOI-Asia Network

- 3 - 4 Satellite Receiver sends the IP packet to Satellite Feed via Receive Router i.e. the local ISP. Note that the IP packet has GRE encapsulated Ethernet frame as it payload.
- 5 The encapsulated Ethernet frame reaches Satellite Feed, and is the original Ethernet frame was extracted. Satellite Feed forwards the Ethernet frame to Feed Router because it is destined to the MAC address of UDL I/F of Feed Router.
- 6 Feed Router receives the Ethernet frame and forwards the IP packet to Destination as if it was directly coming from the satellite UDL.

## 4 SOI-Asia Network Requirement

### 4.1 Hardware

Hardware necessary for installing SOI-Asia network are listed in the table 1. Software is available as ISO images at the specified sources, they should be downloaded and burned to CD-ROMs before start installation. Note that the hardware/software for SOI server, RPT client, WMT client, VIC/RAT and staff machine is separately explained in other documents.

## 5 Connecting Devices

Figure 8 shows a picture of how devices are connected in a receive-only site. By following instructions below, operator will connect hardware listed in the previous section 4.1 to resemble the figure.

**(STEP 1)** Connect satellite cable to UDLR satellite receiver.

- Confirm with satellite vendor that the dish is getting satellite signal and there is an F connector at the end of the cable.

Table 1: Hardware for SOI-Asia Network

Hardware	Amount	Specification
Satellite Receiver	1	
PC (Receive Router)	1	PC/AT compatible FreeBSD 4.x compliant 512MB RAM or more 2GHz CPU or faster Two Ethernet interfaces with reliable chipsets, e.g. Intel (preferred)
Ethernet cables	3	Two 100BASE-TX straight cables One 100BASE-TX crossover cable
Ethernet switch or hub	1	10BASE-T or 100BASE-T NOTE: If Ethernet switch is used, it should be multicast capable. If an intelligent Ethernet switch is used, note that you have to disable IGMP snooping function to avoid the well-know problem regarding Multicast.
LAN Surge Protector	1	Port RJ45 10BT/100BT 2 input/output pairs or more
UPS	1	Surge protection capability Online-type 3 outlets or more
Power Surge Protector	2	Each has 6 outlets or more
Console cable	1	

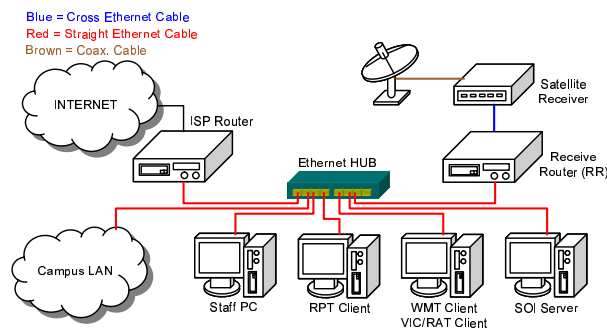

Figure 8: Connecting Devices in Receive-Only Site

- Connect F connector to the ANT IN port at the backside of UDLR satellite receiver.

**(STEP 2)** Connect UDLR satellite receiver to RR.

- Connect UDLR satellite receiver's Ethernet interface to one of RR's Ethernet interfaces by a crossover cable ;no hub or switch required in between;. Place the LAN surge protectors between both ends of cable and Ethernet ports.
- Connect another Ethernet interface of RR and Ethernet interfaces of other machines to a prepared hub/switch by Ethernet cables (e.g. 10BASE-T, 100BASE-T).

**(STEP 3)** Connect machines to LAN.

- Connect another interface of RR to the hub using straight cable.
- Connect local interface of ISP router to the hub using straight cable.
- Connect LAN interfaces of other machines to the hub using straight cable; this step can be done later when you are setting them up.

**(STEP 4)** Connect power cables.

- Connect UDLR satellite receiver's and RR's power cables to the UPS instead of connecting them directly to power line.
- Connect SOI-Asia server to the UPS instead of connecting them directly to power line.
- For all other machines and devices in SOI-Asia environment, connect their power cables to the power surge protector before going directly to power line.

## 6 IPv4 address and Hostname Assignment

SOI-Asia network uses three sets of IPv4 addresses: SOI-Asia global address, local ISP's global address and campus private LAN address. SOI-Asia assigns one global IPv4 address to RR's UDL interface. The following URL gives information about IP address assignment to your organization.

**URL** <http://www.soi.wide.ad.jp/project/soi-asia/sitesetup/soiasia-address-list.doc>.

The table 2 describes, as example, how these IPv4 address sets are assigned to the subnets in each receive-only site.

Note that the prefix of private IPv4 address of UDL, which is necessary for communication between the satellite receiver and the receiver router, is determined by the following convention.

### Convention

The fourth octet of the receive router's IPv4 address is employed on the third octet of the prefix of private address on UDL.

Table 2: Example of IP Address Assignment in Receive Only Site

Assigned From	Purpose	Type	Network Address
SOI-Asia	LAN	Global	202.249.26.0/29
SOI-Asia	UDL	Global	202.249.25.194/27
SOI-Asia	UDL	Private	192.168.194.0/24
Local ISP	LAN	Global	133.27.16.0/30
Campus	LAN	Private	10.0.0.0/8

Table 3: Example for Determining Prefix of Private Address

Receive Router IP Address	202.249.25.194/27
Prefix of Private Address	192.168.194.0/24

Table 4: Example of IP Address Assignment to Each Host

	SOI-Asia Global	SOI-Asia Private	Local ISP	Campus LAN
Satellite Receiver		192.168.194.1		
Receive Router(UDL)	202.249.25.194	192.168.194.2		
Receive Router (LAN)	202.249.26.1		133.27.16.1	
ISP Router			133.27.16.2	
SOI Server	202.249.26.2			10.0.1.1
WMT Client	202.249.26.3			
RPT Client	202.249.26.4			
VIC/RAT or Polycom	202.249.26.5			
Staff PC	202.249.26.6			
Other PCs				10.x.x.x

The table 3 shows the example of determining a prefix.

The table 4 describes how IP addresses are assigned to each machine in each receive-only site. Note that some machines such as Receive Router or SOI server have multiple IP addresses on one network interface.

The table 5 shows how hostnames are set on machines in the receive-only site assuming that its site name is "SFC".

Table 5: Sample Hostname Setting

Machine	Hostname
Satellite Receiver	(no hostname)
Receive Router	sfc-udl-recv.ai3.net
ISP Router	(no hostname for SOI-Asia)
SOI Server	sfc-soi.ai3.net
WMT Client	sfc-wmt.ai3.net
RPT Client	sfc-rpt.ai3.net
VIC/RAT or Polycom	sfc-vicrat.ai3.net
Other PCs	sfc-c1.ai3.net / sfc-c2.ai3.net / ...

## 7 Network Address Transration in SOI-Asia Network

Network Address Transration (NAT) is the application which converts the srouce address of IP datagrams from the original sender's private IP address to the router's global IP address on which NAT is activated. This application is introduced many enterprise networks to reduce the usage of global IP addresses providing global connectivity to many nodes in the private networks. SOI-Asia network requires NAT for the different purpose from other enterprise networks.

As described in the section 3.4 and the table 4 in the section 6, GRE encapsulated packets will go through the Internet with its souce IP address is the private IP address of Satellite Receiver. However, it is often the case that packets origined by private IP address is dropped in ISPs. Also, if local ISP receives packets which seem not to be originated from their customer network, those packet could be dropped. Therefore, the GRE encapsulated packets from Sastellite Receivers could be dropped before they reach the end-point of LLTM. To avoid this problem, SOI-Asia installs NAT in Receive Router like the figure 9.

NAT in Receiver Router converts the source address GRE packets from Satellite Receiver's private IP address to Receive Router's global IP address, which belongs not to SOI-Asia but to Local ISP. Then it could be expected that the GRE encapsulated packets originally from Satellite Receiver reach the Satellite Feed in SFC via Local ISP and the Internet.

## 8 SOI Asia RR Installation Lab Work

### 8.1 Kernel installation

In this step you will prepare a new kernel for RR

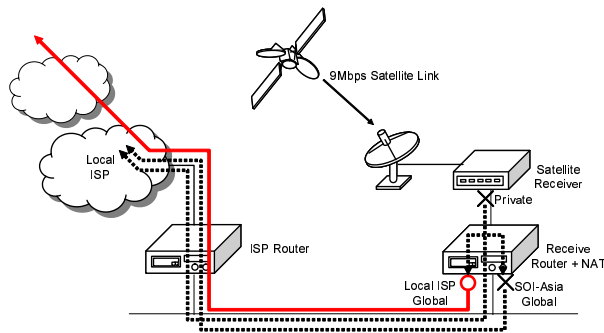

Figure 9: Activate NAT on Receive Router

1. Copy the Generic kernel configuration to the SOI Asia RR kernel configuration.  

```
cd /usr/src/sys/i386/conf
cp GENERIC SOIASIA
```
2. Edit the SOI Asia RR kernel, and add the following lines.

```
options      MROUTING
options      PIM
options      IPFILTER
```

3. Compile and install the SOI Asia RR kernel.

```
config SOIASIA
cd ../compile/SOIASIA
make depend
make
make install
```

4. Confirm that kernel is installed.
5. Disable Zebra and XORP boot scripts.  

```
chmod -x /usr/local/etc/rc.d/zebra.sh
chmod -x /usr/local/etc/rc.d/xorp.sh
```

## 8.2 Network configuration

1. Set network configuration in `/etc/rc.conf`. Please follow the IP addresses given by the instructor.  
EXAMPLE: The IP addresses below are for **soi11** user.

```
hostname=11-rr.ai3.net
ifconfig_em0="202.249.25.212 netmask 255.255.255.224 mtu 1452
ifconfig_em0_alias0="192.168.0.11 netmask 255.255.255.0
ifconfig_em1="202.249.24.105 netmask 255.255.255.248"
ifconfig_em1_alias0="200.200.11.1 netmask 255.255.255.0"
ifconfig_em1_alias1="10.10.0.1 netmask 255.255.255.0
defaultrouter="202.249.25.193
```

```

static_routes="feedlltm"
route_feedlltm="-host 202.249.25.98 200.200.11.200"
gateway_enable="YES"
ipv6_enable="YES"
ipv6_gateway_enable="YES"
ipv6_ifconfig_em0="2001:0D30:0101:5::EF:1:1 prefixlen 64"
ipv6_ifconfig_em1="2001:0D30:1EF:1::1 prefixlen 64"
rtadvd_enable="YES"
rtadvd_interfaces="em1"

inetd_enable="NO"
kern_securelevel_enable="NO"
nfs_reserved_port_only="NO"
sendmail_enable="NONE"
sshd_enable="YES"
usbd_enable="NO"

ipfilter_enable="YES"
ipfilter_rules="/etc/ipf.rules"
ipmon_enable="YES"
ipmon_flags="-Ds"

ipnat_enable="YES"
ipnat_rules="/etc/ipnat.rules"

```

2. Configure IPFILTER rules in `/etc/ipf.rules`

```

pass in quick all
pass out quick all

```

3. Configure NAT rules in `/etc/ipnat.rules` Please follow the IP addresses given by the instructor.  
EXAMPLE: The IP addresses below are for **soi11** user.

```

map em1 192.168.0.1 -> 200.200.11.1

```

4. Configure DNS resolver in `/etc/resolv.conf`

```

domain ai3.net
nameserver 202.249.24.34
nameserver 202.249.24.33

```

5. Shutdown your machine.  
`shutdown -p now`  
TA will change the network topology and then restart your machine.
6. After reboot, log on as root and confirm that the new kernel is running.  
`uname -a`

### 8.3 Verify the connectivity

1. Logon as root.
2. Check the network interfaces.  
`ifconfig -a`

3. Check the routing table.  

```
netstat -nrf inet
```
4. Check connectivity to UDLR receiver.  

```
ping -c 10 192.168.0.1
```
5. Check connectivity to your ISP router using ping.
6. Check connectivity to UDL feed.  

```
ping -c 10 202.249.25.193
```
7. Check the operation of NAT.  

```
tcpdump -npi em0 proto gre
```

You should see some GRE packets, then stop `tcpdump`.  
Run `tcpdump` on the `em1` interface.  

```
tcpdump -npi em1 -c 10 proto gre
```

Check whether the source addresses of GRE packets are changed into the ISP address of the router.
8. Check connectivity to other IPv6 routers on UDL.  

```
ping6 ff02::1%em0
```

## 8.4 Configure IPv6 unicast routing with Zebra

You will edit Zebra and Ospf6d configurations to follow the SOI Asia network design.

1. Confirm your Zebra configuration. You don't need to edit it.  

```
vi /usr/local/etc/zebra.conf
```
2. Edit your Ospf6d configuration.  

```
vi /usr/local/etc/ospf6d.conf
```
3. Change interface costs and priorities.  
Interface cost is 50. The priority is 0 for the interface toward UDL (`em0`), and 100 for the interface toward your site (`em1`).

```
interface em0
  ipv6 ospf6 cost 50
  ipv6 ospf6 priority 0
!
interface em1
  ipv6 ospf6 cost 50
  ipv6 ospf6 priority 100
```

4. Change the router ID based on the topology given by the instructor.

```
router ospf6
  router-id A.B.C.D
  interface em0 area 0.0.0.0
  interface em1 area 0.0.0.0
```

5. Save your configuration.

6. Run Zebra and Ospf6d.  

```
/usr/local/sbin/zebra -d
/usr/local/sbin/ospf6d -d
```

Your Zebra and Ospf6d should be running if you don't see any error messages.
7. Confirm that Zebra and Ospf6d processes are running.  

```
ps -ax
```
8. Access Ospf6d CLI and run the following commands.  

```
show ipv6 ospf6 interface
show ipv6 ospf6 neighbor
show ipv6 ospf6 route
```
9. Quit from Ospf6d CLI.
10. Check the IPv6 routing table.  

```
netstat -nrf inet6
```

You should see many entries.
11. Activate the Zebra boot script.  

```
chmod +x /usr/local/etc/rc.d/zebra.sh
```

## 8.5 Configure PIM-SMv6 using XORP

You will edit the XORP configuration to follow the SOI Asia network design for PIM-SMv6

1. Stop XORP if is currently running.  

```
/usr/local/etc/rc.d/xorp.sh stop
```
2. Check your XORP configuration.
3. Run XORP to confirm your configuration.  

```
/usr/local/xorp/bin/xorp_rtmgr &
```

Fix your configuration file if you find errors.
4. Access XORP CLI.  

```
/usr/local/xorp/bin/xorpsh
```
5. Check the results of the following commands.  

```
show pim6 interface
show pim6 neighbors
```
6. Quit from XORP CLI.  

```
quit
```
7. Join a multicast group.  

```
remote-mcast-server 1500 &
remote-mcast-cmdline localhost 1500 "j6 ff38:20:2001:d30:101::555
em1"
```
8. The instructor runs a multicast stream.

9. Check whether you receive the stream.  
`/usr/local/xorp/bin/xorpsh`  
`show pim6 join`  
`show pim6 mfc`  
Analyze your findings.
10. Quit from XORP CLI.  
`quit`
11. Check the kernel multicast forwarding cache.  
`netstat -ngf inet6`
12. Check whether IP multicast traffic flows out of em1 interface.  
`tcpdump -npi em1 'ip6 multicast'`

## 8.6 Final check

You will check whether every configurations work correctly.

1. Reboot your router.
2. After reboot, logon as root.
3. Check whether all processes are running.
4. Check the network interfaces.
5. Check the routing table for IPv4 and IPv6.
6. Check the multicast operation.

## Introduction to SOI-Asia Network

- AI<sup>3</sup> Project Overview
- SOI-Asia Network Overview
- UDLR Overview (Specification)
- UDLR in SOI-Asia Network (Implementation)
- Requirements for Developing SOI-Asia Network



1

## Before we go in detail on AI<sup>3</sup> and SOI-Asia Network...

- In general, satellite links have
  - Wide coverage without geographical limitation
  - Broadcast capability
  - Flexibility on link configuration
    - Frequency, information rate, etc...



2

## Earth Station Receive-Only v.s. Transmit-Capable (Original)

	Receive-Only	Transmit-Capable
Cost of building earth station	Cheap	Expensive
Size of earth station system	Small because of simple composition	Large because of many equipments
Transmission license	No need in most countries	Need and difficult to obtain
Radio specialist	No need	Need specialist always standing by

3

## Earth Station Receive-Only v.s. Transmit-Capable

	Receive-Only	Transmit-Capable
Cost	Reasonable	Expensive
Size	Small	Large
Transmission license	No need in most countries	Need and difficult to obtain
Radio specialist	No need	Need specialist always standing by

4

## AI<sup>3</sup> Project Overview



5

## What is AI<sup>3</sup> Project?

- Asian Internet Interconnection Initiatives
  - An international research consortium among research institutes in Asian region
  - Started in 1995
- Objective
  - To form a group of researchers to develop leading edge technologies for the Internet
- Supporting SOI-Asia project from the view point of network infrastructure

6

### Partners List (original)

- AI<sup>3</sup> partners (Connected by BDL)
  - AIT (Thailand)
  - ITB (Indonesia)
  - TP (Singapore)
  - USM (Malaysia)
  - IOIT (Vietnam)
  - ASTI (Philippines)
  - KEIO (Japan)
  - NAIST (Japan)
- SOI-Asia partners (Connected by UDL)
  - 4 from Indonesia
  - 3 from Thailand
  - 1 from Philippines
  - 1 from following countries
    - Malaysia
    - Laos
    - Myanmar
    - Cambodia
    - Bangladesh
    - Mongolia
    - Nepal
- Some AI<sup>3</sup> Partners

### Partners List

- AI<sup>3</sup> partners (Connected by BDL)
  - AIT (Thailand)
  - ITB (Indonesia)
  - TP (Singapore)
  - USM (Malaysia)
  - IOIT (Vietnam)
  - ASTI (Philippines)
  - KEIO (Japan)
  - NAIST (Japan)
- SOI-Asia partners (Connected by UDL)
  - 4 from Indonesia
  - 3 from Thailand
  - 1 from Philippines
  - 1 each from following countries
    - Malaysia
    - Lao PDR
    - Myanmar
    - Cambodia
    - Bangladesh
    - Mongolia
    - Nepal
- Some AI<sup>3</sup> Partners

### AI<sup>3</sup> Network in the Map

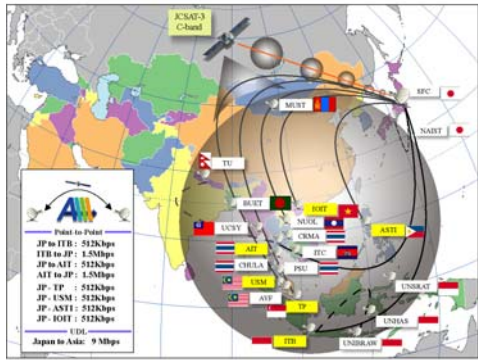

### AI<sup>3</sup> Network Topology

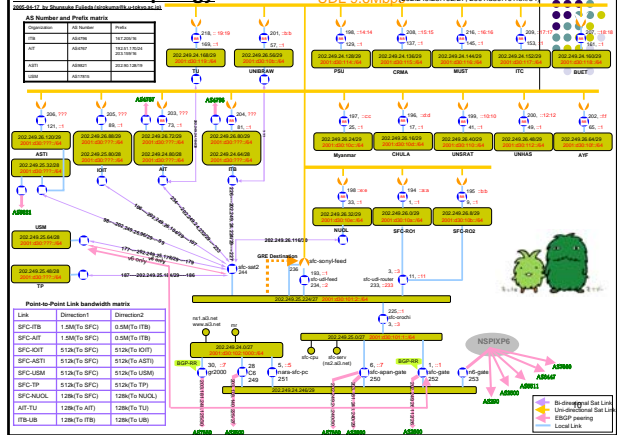

### AI<sup>3</sup> External Peering

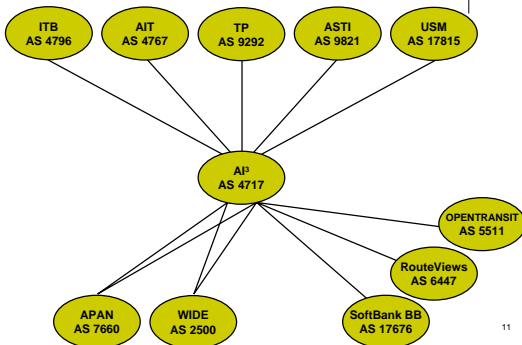

### SOI Asia Network Overview

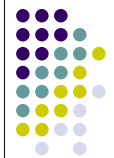

### What is SOI-Asia Network? (original)

- Network infrastructure for SOI-Asia activity
  - Deliver real-time lectures to SOI-Asia partners
  - Accommodate traffic for daily life
  
- Composed of several machines with specialized services and functions
  
- Operation body
  - AI<sup>3</sup>/SOI-Asia network operators



### What is SOI-Asia Network?

- Network infrastructure for SOI-Asia activity
  - Distribute real-time lectures to SOI-Asia partners
  - Accommodate traffic for daily life
  
- Composed of several machines with specialized services and functions
  
- Operation body
  - AI<sup>3</sup>/SOI-Asia network operators



### Using Satellite link as Uni-Directional Link (UDL) (original)

- A satellite network which is composed of:
  - One transmit-capable stations
  - Many receive-only stations

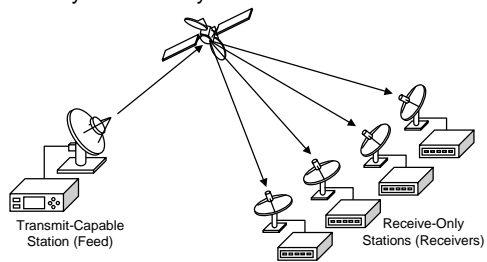

### Using Satellite Link as Uni-Directional Link (UDL)

- A satellite network which is composed of:
  - One transmit-capable stations
  - Many receive-only stations

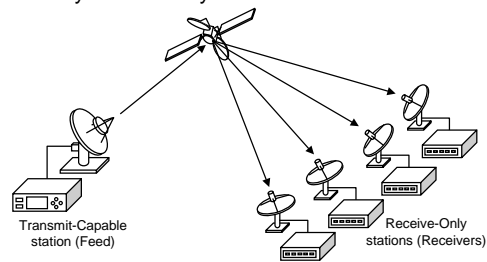

### SOI Asia Network Topology

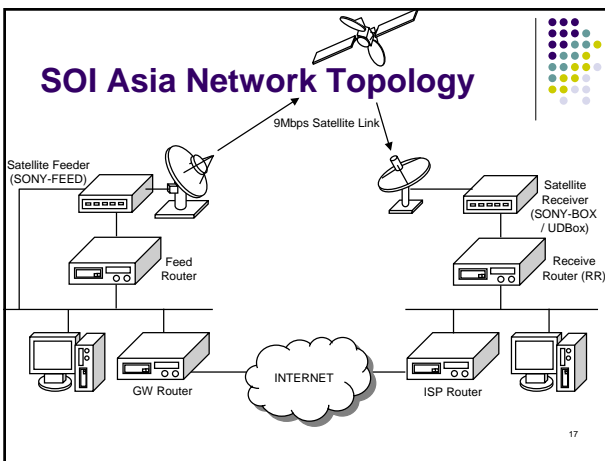

### Standard Network Topology of SOI Asia RO Site

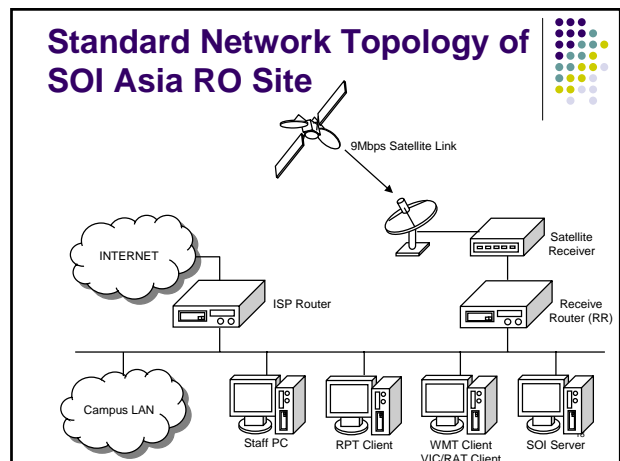

## Is SOI-Asia Network Strange? Why?

Husni, please try  
"tracert www.ai3.net"  
from VIC/RAT PC



19

## Is SOI-Asia Network Strange? Why?

Husni, please try  
"tracert ayf-udl-recv.ai3.net"  
from VIC/RAT PC



20

## Before we go in detail of how SOI-Asia network works.... (original)

- 3 Generic Types of Data Link in the Internet
  - Point-to-Point
  - Broadcast Multiple Access
  - Non-Broadcast Multiple Access



21

## Before we go in detail of how SOI-Asia network works....

- 3 generic types of data link in the Internet
  - Point-to-Point
  - Broadcast (multiple access)
  - Non-Broadcast Multiple Access



22

## Point-to-Point (original)

- Only 2 nodes on the link
  - Nobody else to send a packet
  - MAC address is not necessary on Point-to-Point link
  - Bi-directional
- Examples
  - Serial Connection
  - Digital dedicated line



23

## Point-to-Point

- Only 2 nodes on the link
  - Nobody else to send a packet
  - MAC address is not necessary on Point-to-Point link
  - Bi-directional
- Examples
  - Serial connection
  - Digital dedicated line
  - Dial-up connection



24

### Broadcast Multiple Access (original)

- Multiple nodes connects on the link
  - A packet is broadcasted to all nodes on the link
  - Requires MAC address resolution
  - Bidirectional
- Example
  - Ethernet

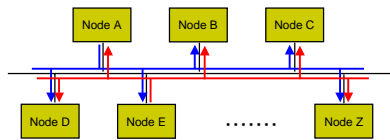

25

### Broadcast (Multiple Access)

- Multiple nodes connects on the link
  - A packet is broadcasted to all nodes on the link
  - Requires MAC address resolution
  - Bi-directional
- Example
  - Ethernet

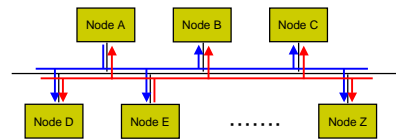

26

### Non-Broadcast Multiple Access (original)

- Multiple nodes connects on the link
  - Data is delivered to a single or multiple nodes
  - No broadcast capability
  - Bi-directional
- Example
  - ATM (Asynchronous Transfer Mode)

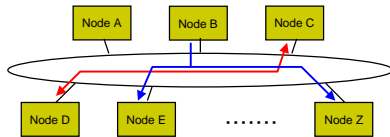

29

### Non-Broadcast Multiple Access

- Multiple nodes connects on the link
  - Data is delivered to a single or multiple nodes
  - No broadcast capability
  - Bidirectional
- Example
  - ATM (Asynchronous Transfer Mode)

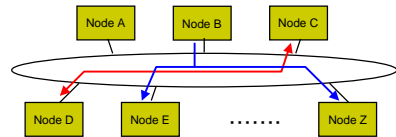

30

### Problem on SOI-Asia Network (original)

- We're using satellite link as UDL
  - Not categorized in none of previous 3 link types
- What does it mean, actually?
  - Send-only node can't find other nodes on the link
  - Receive-only node can find other nodes on the link but can't transmit any packets
- One-way link is unexpected in the Internet
  - Routing protocols
  - Address resolution (ARP, NDP)
  - Transport protocols and applications

29

### Problem on SOI-Asia Network

- We're using satellite link as UDL
  - Not categorized in none of previous 3 link types
- What does it mean, actually?
  - Send-only node can't find other nodes on the link
  - Receive-only node can find only send-capable node but no other receive-only nodes
- One-way link is unexpected in the Internet
  - Routing protocols
  - Address resolution (ARP, NDP)
  - Transport protocols and applications

30

### Example: ARP (original)

- Assumption of the Internet
  - Data link is bi-directional
- Process to communication between A and B
  - A requests the MAC address of B (ARP Request)
  - B answers its MAC Address to A (ARP Reply)
  - A know the destination interface

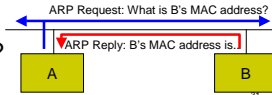

- No ARP Reply from B?



### Example: ARP

- Assumption of the Internet
  - Data link is bi-directional
- Process to communicate between A and B
  - A requests the MAC address of B (ARP request)
  - B answers its MAC address to A (ARP reply)
  - A knows the destination interface MAC address

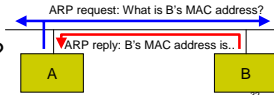

- No ARP Reply from B?



## UDLR Overview

Specification

Why packets could come and go on the one-way link?



## What is UDLR?

- Uni-Directional Link Routing
  - Specified as "A Link-Layer Tunneling Mechanism for Unidirectional Links" in RFC3077
- Objectives
  - To allow nodes to communicate on a uni-directional link
- Approach
  - Deliver a packet from receive-only node to send-capable node via the Internet
  - To emulate Broadcast Multiple Access link on a uni-directional link

## Definition of Links and Nodes

- Links
  - UDL: Uni-directional Link
  - BDL: Bi-directional Link (LAN Connectivity to the Internet)
- Nodes
  - Send-only Feed: A router that has send-only connectivity to a UDL
  - Receiver: A router or a host that has receive-only connectivity to a UDL
- Assumption
  - Both Send-only Feed and Receiver has BDL connection



## Physical Connection (original)

- Each Node is belonging to the different LAN
  - Can't directly communicate with others on UDL

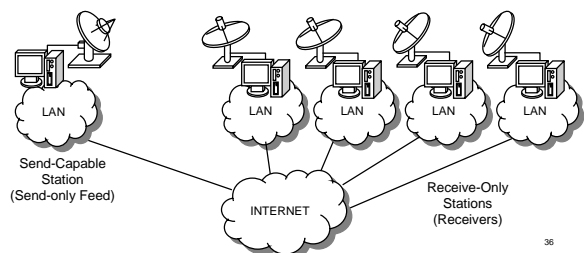

### Physical Connection

- Each Node is belonging to the different LAN
  - Can't directly communicate with others on UDL

37

### Logical Connection with UDLR

- Every node connects to the single subnet
- The subnet works like Ethernet
  - Bidirectional
  - Broadcast Multiple Access

38

### Logical Connection with UDLR

- Every node connects to the single subnet
- The subnet works like Ethernet
  - Bi-directional
  - Broadcast Multiple Access

39

### UDLR as Collection of 3 Technologies

40

### UDLR as Collection of 3 Technologies

41

### Link Layer Tunneling Mechanism (LLTM)

42

### What is LLTM?

- Give virtual "Send Capability" to Receiver on the UDL
  - Emulate direct bi-directional communication between Send-only Feed and Receiver on UDL
- Each Receiver establishes Link Layer Tunnel with Send-only Feed
  - Data link frame from Receiver is delivered to UDL I/F of Send-only Feed via the Internet
- Send-only Feed processes the data link frame as if it were directly received from Receiver over UDL

43

### Packet from Receiver to Send-only Feed

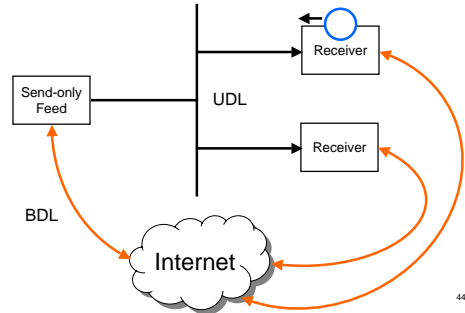

44

### Packet from Receiver to Send-only Feed

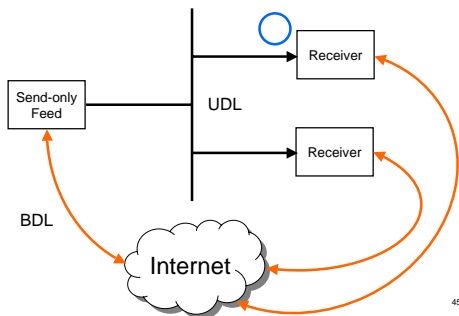

45

### Packet from Receiver to Send-only Feed

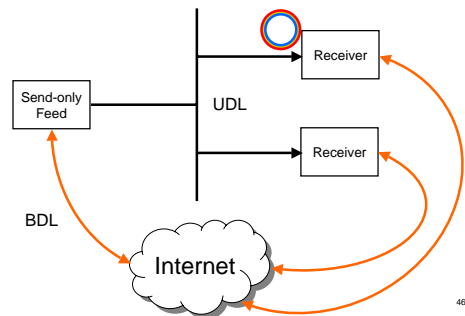

46

### Packet from Receiver to Send-only Feed

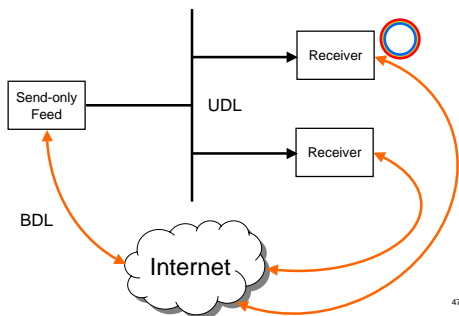

47

### Packet from Receiver to Send-only Feed

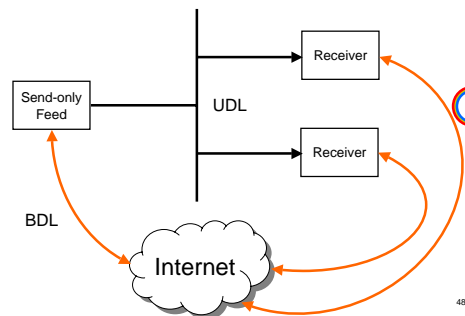

48

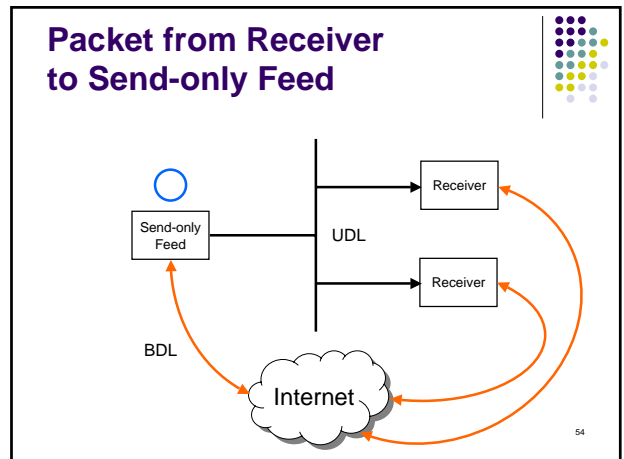
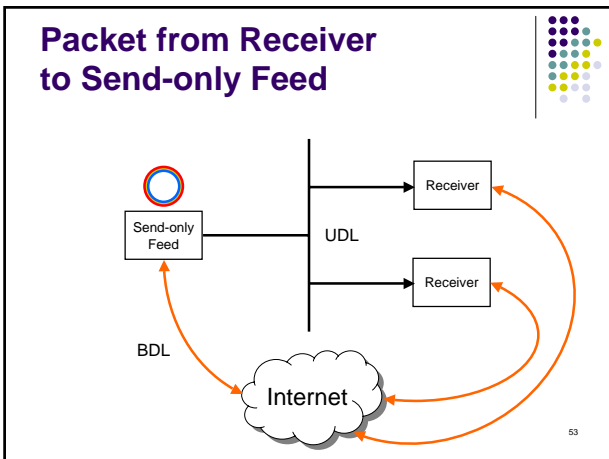
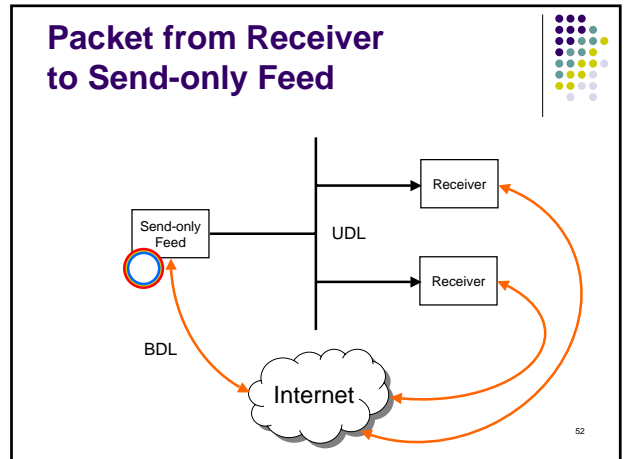
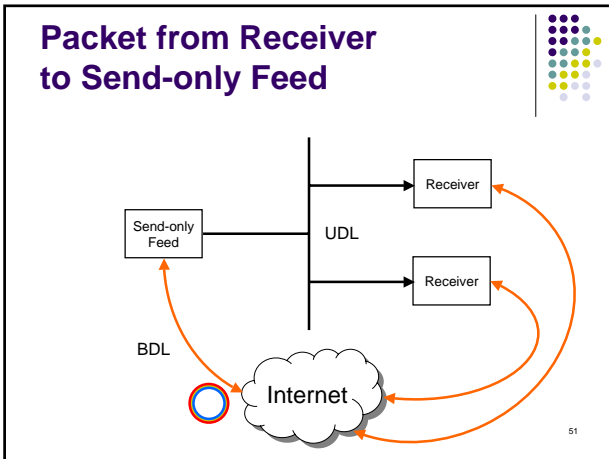
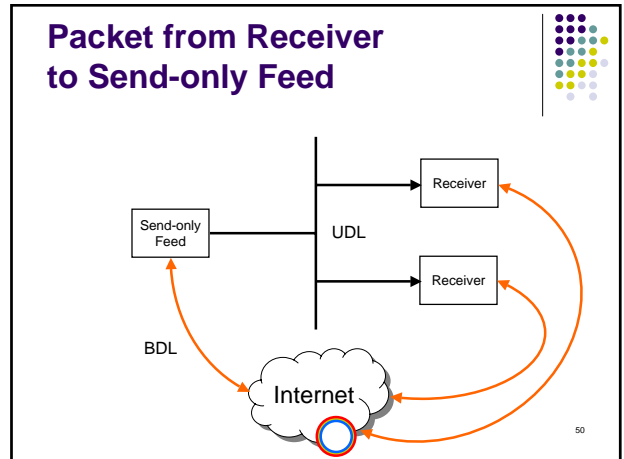
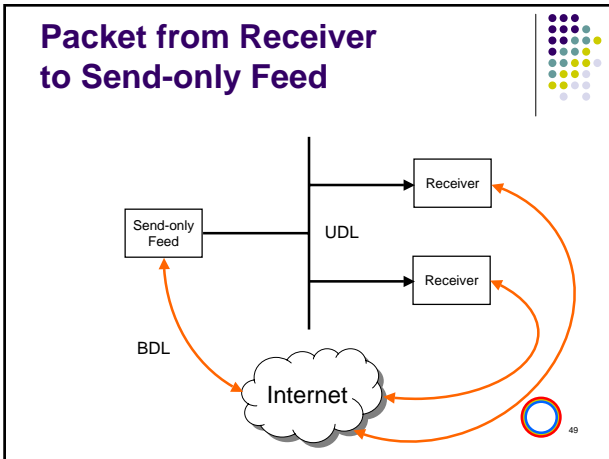

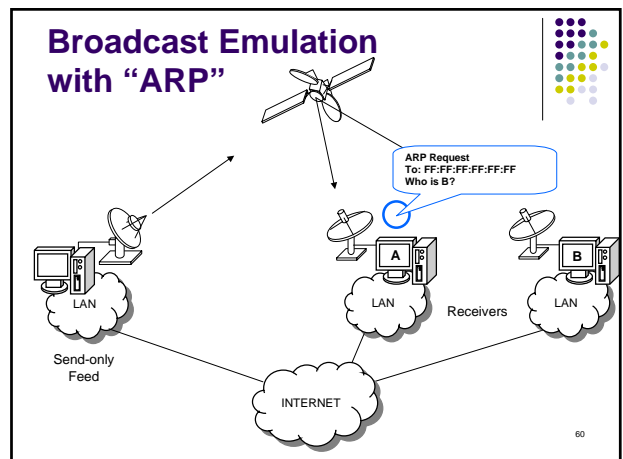
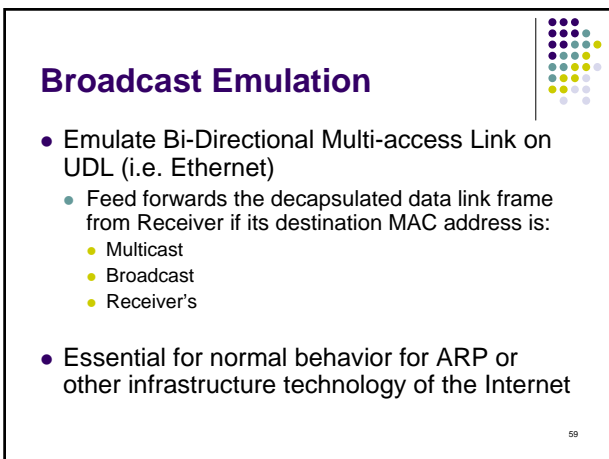
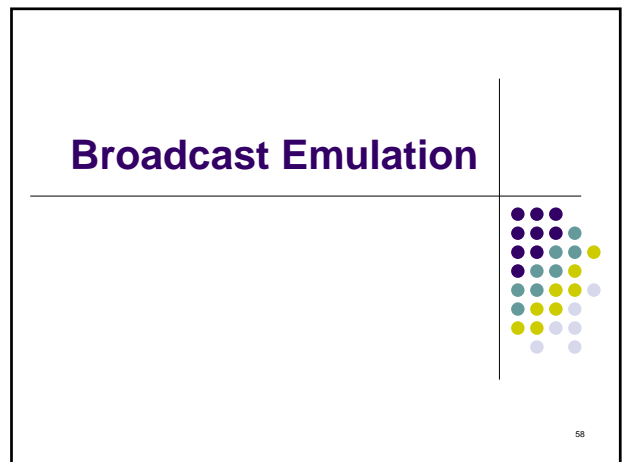
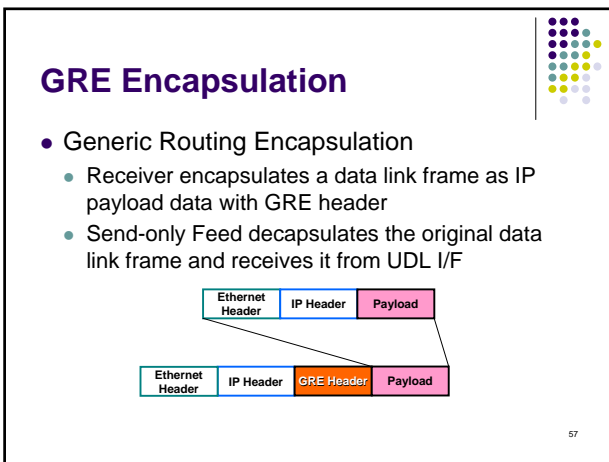
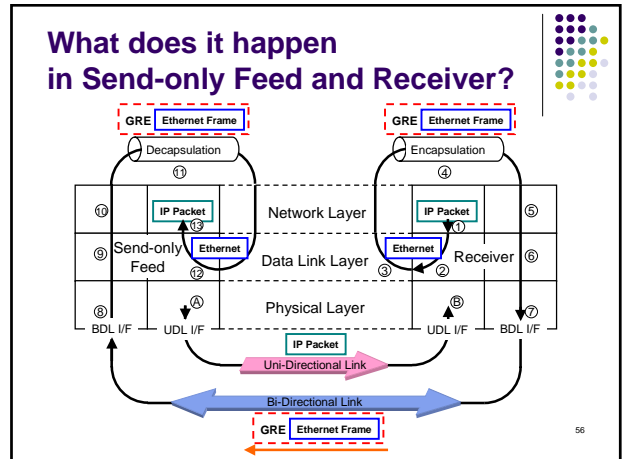
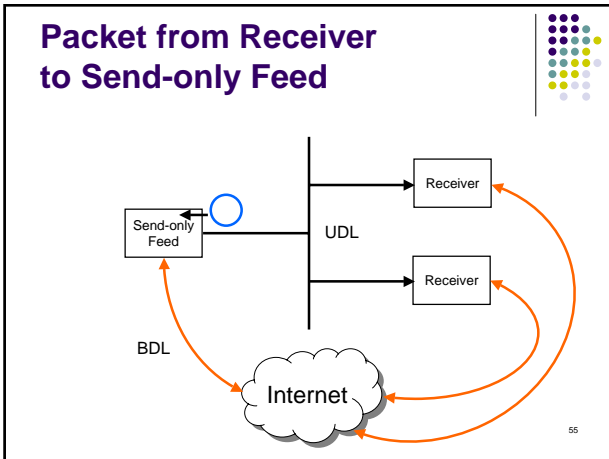

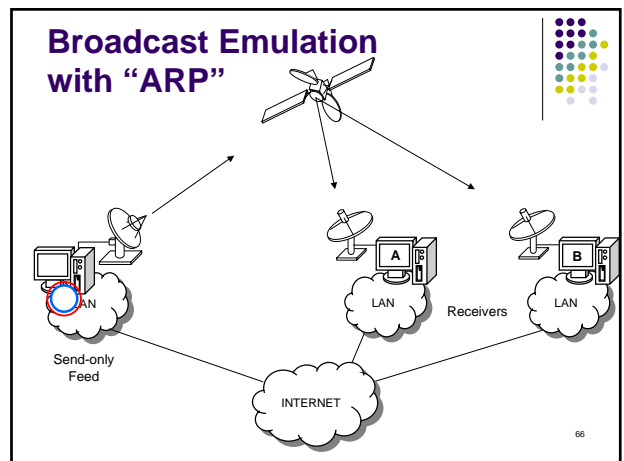
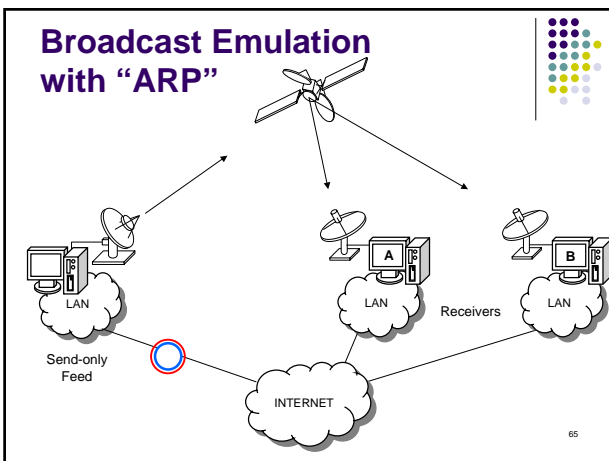
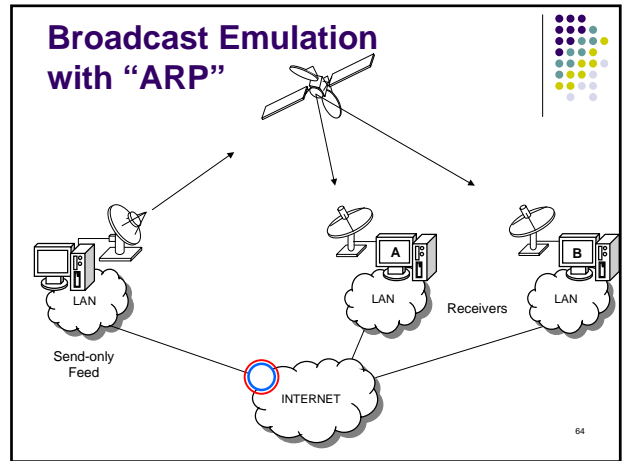
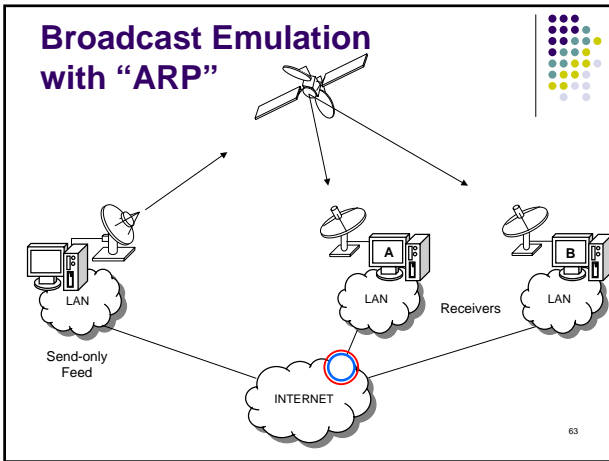
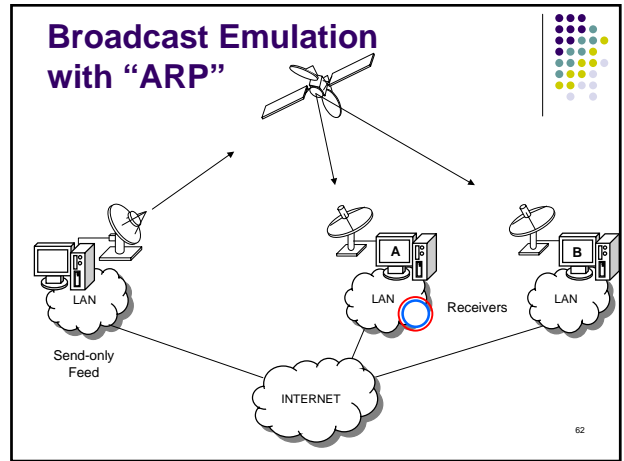
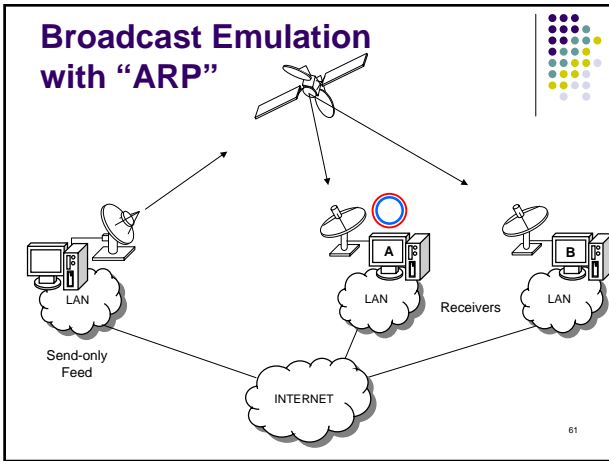

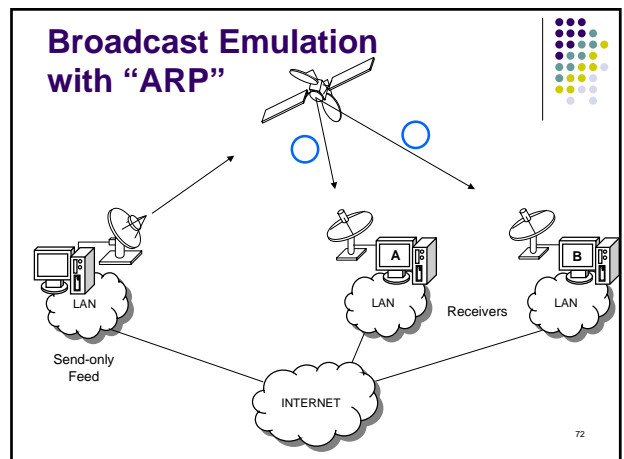
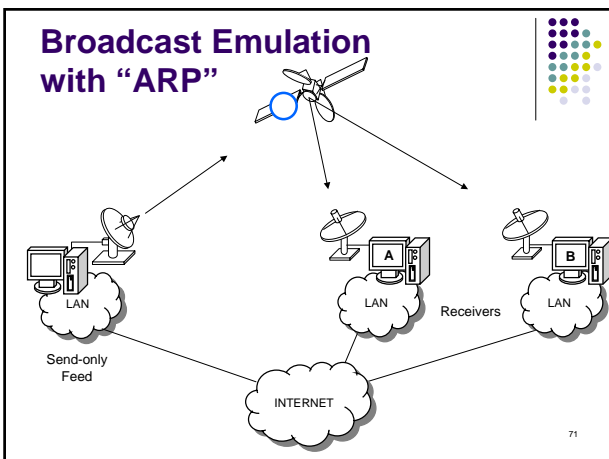
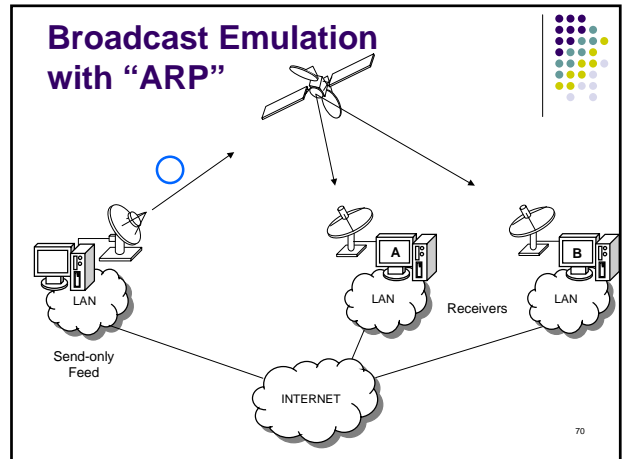
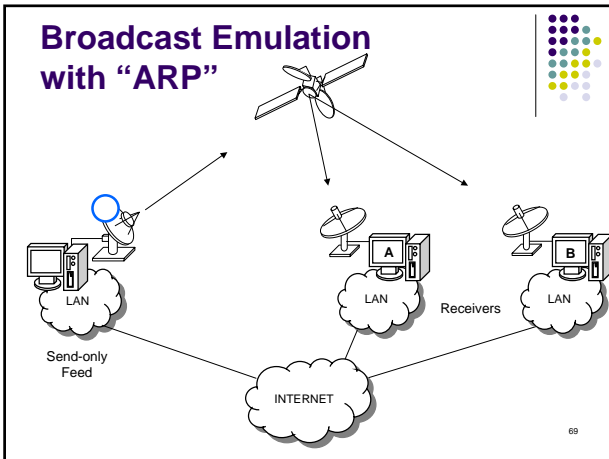
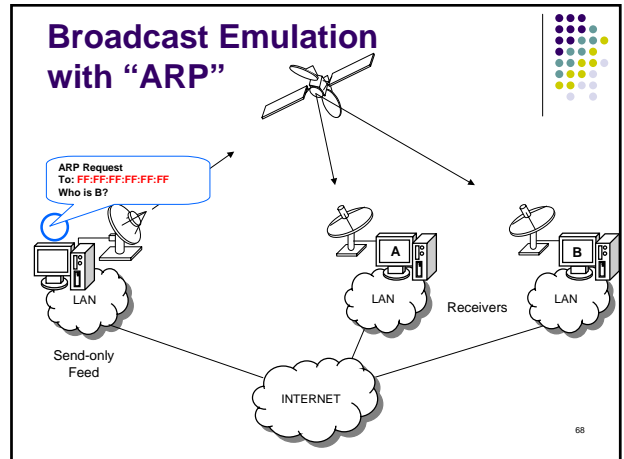
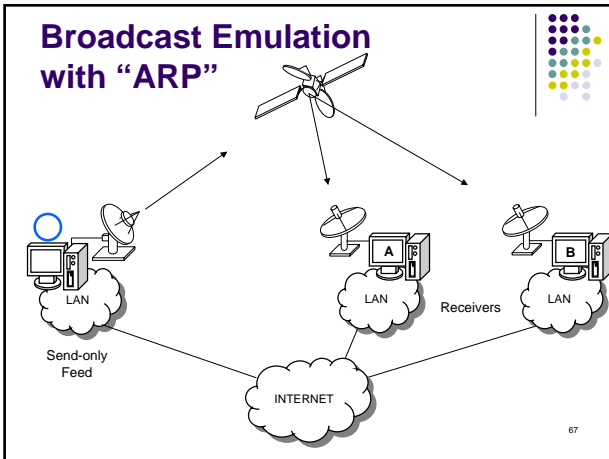

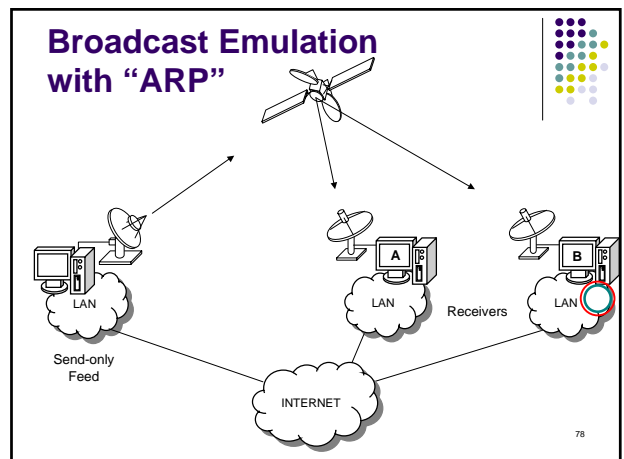
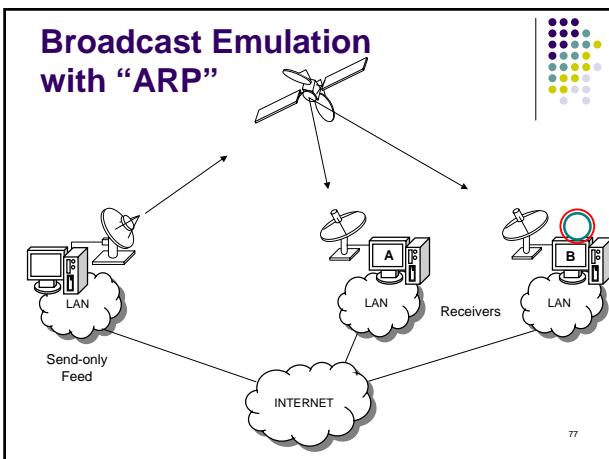
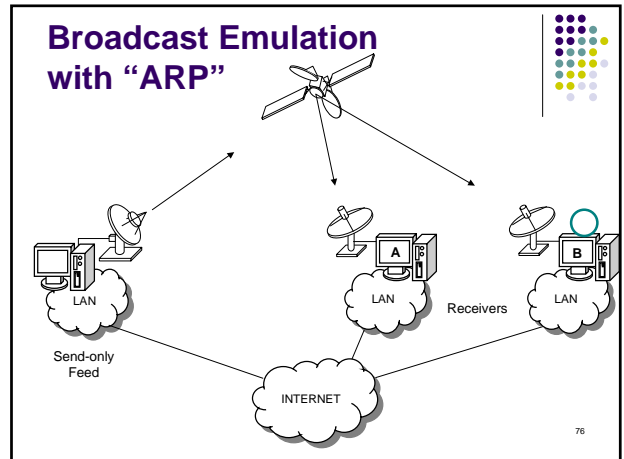
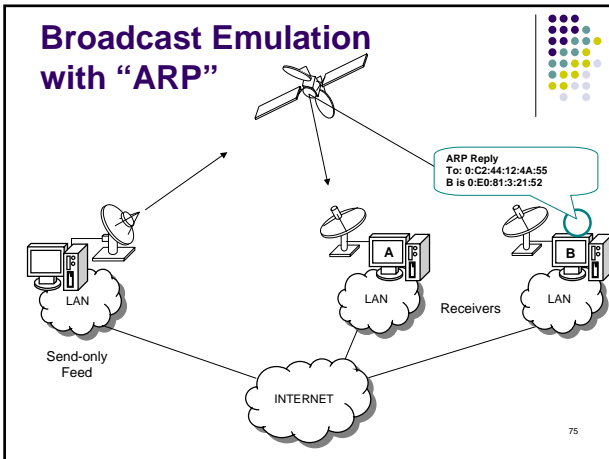
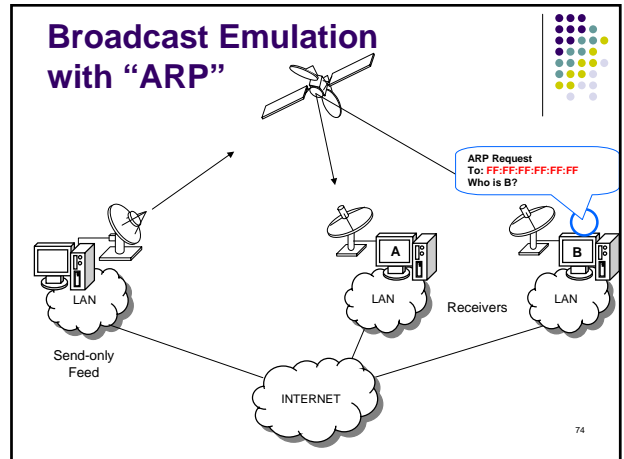
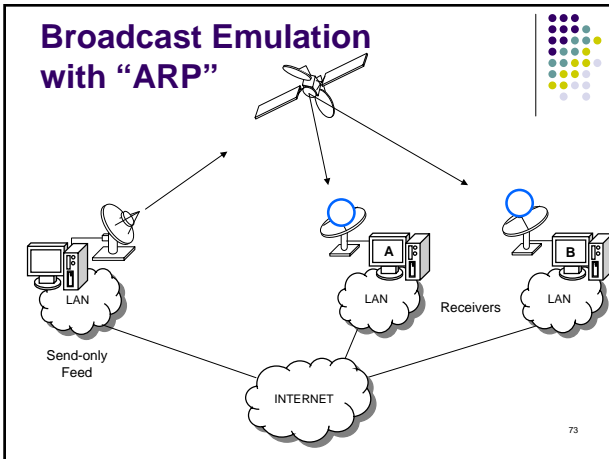

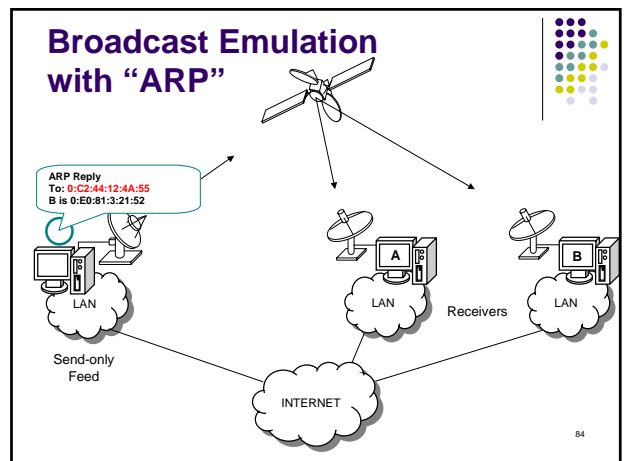
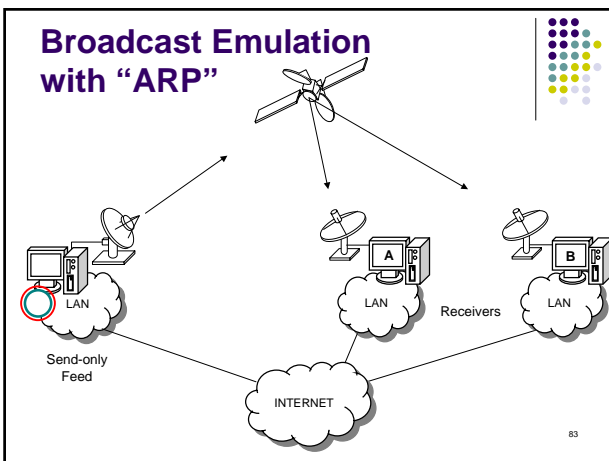
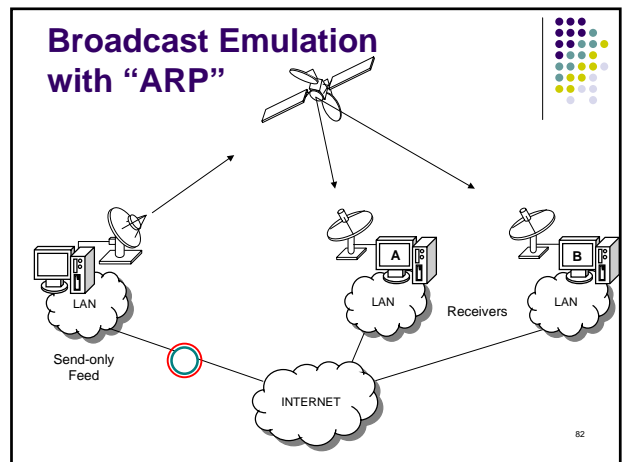
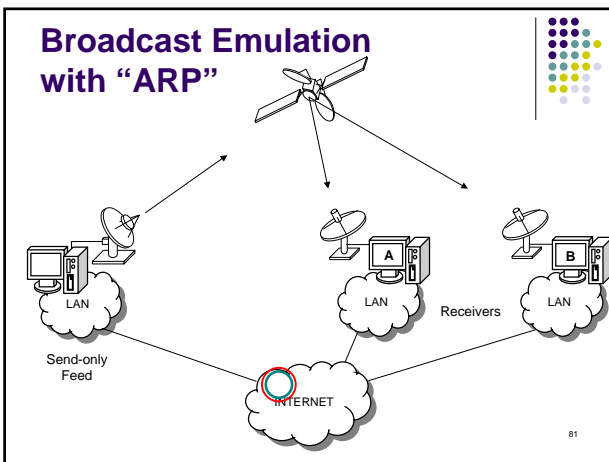
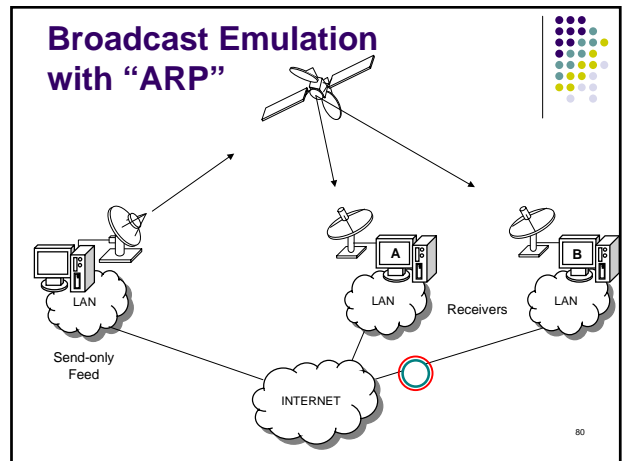
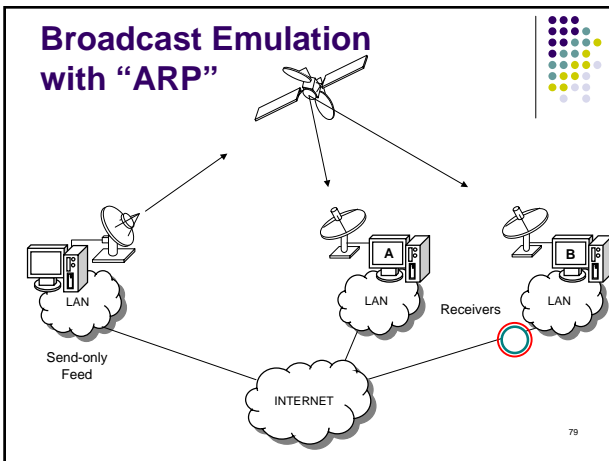

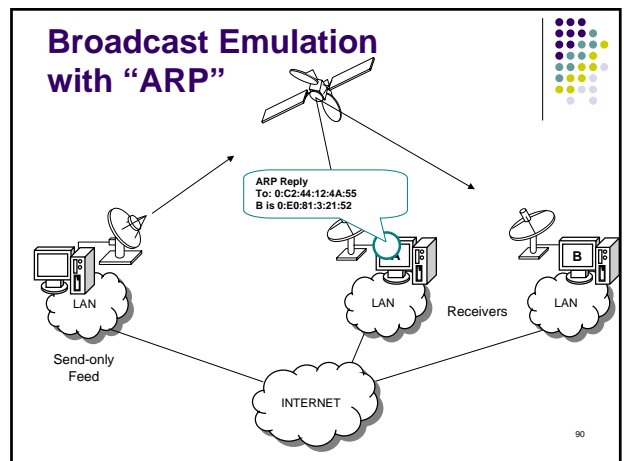
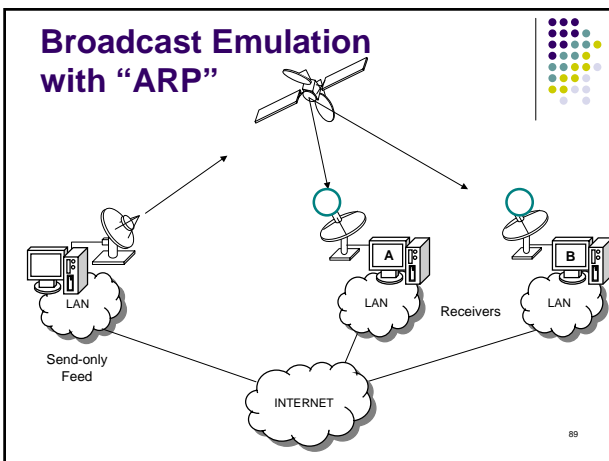
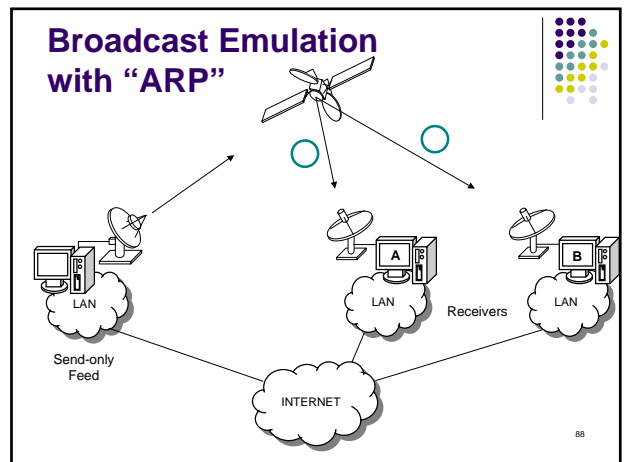
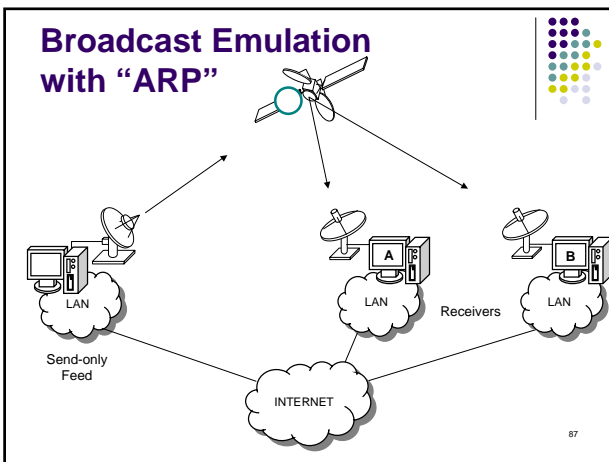
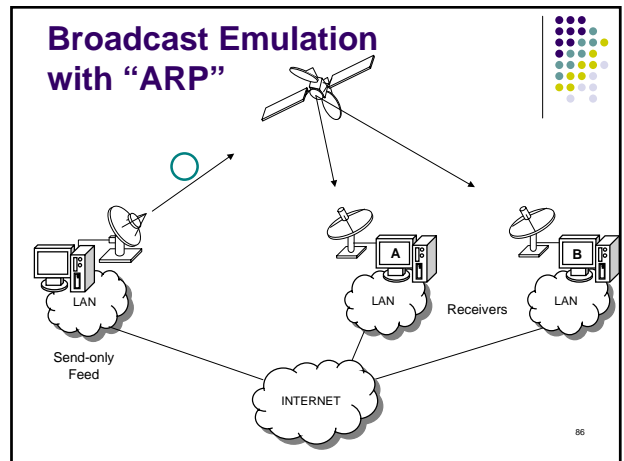
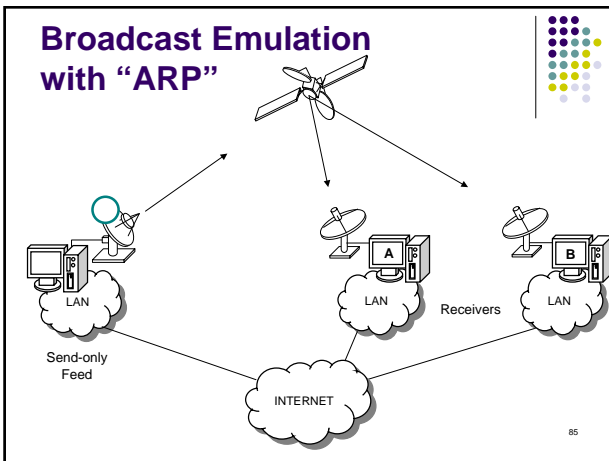

## Dynamic Tunnel Configuration Protocol

91

## What is DTCP?

- One-way Protocol
  - Send-only Feed advertises the end point of LLTM to Receivers
  - Receivers learn the end point of LLTM to send the GRE packets
- DTCP HELLO Packet
  - Advertise IP Address of BDL I/F on UDL Feed
  - Periodic
    - Feed Up / Down, Join / Leave
    - UDL Up / Down
  - Destination IP Address: 224.0.0.36
  - Destination Port: 652

92

## UDLR Review! (original)

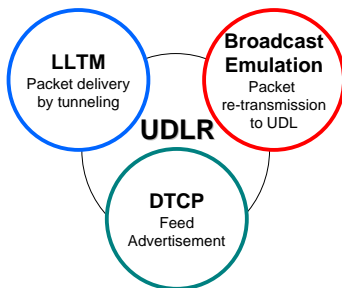

93

## UDLR Review!

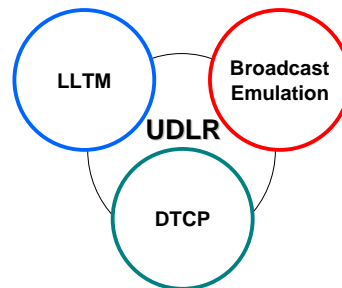

94

## UDLR in SOI-Asia Network

Implementation

95

## Difference between Specification and Implementation

- Specification: Send-only Feed
- Implementation: Satellite Feed + Feed Router
- Specification: Receiver
- Implementation: Satellite Receiver + Receive Router

96

### Satellite Receivers (original)

- A satellite receiver for SOI Asia Network
  - Input radio wave from satellite UDL on Coax. Interface
  - Output Ethernet frames from LAN Interface
  - Provide Receiver functions of UDLR
    - GRE encapsulation
    - DTCP client
  - UDBox, SONY-BOX

97

### Satellite Receivers

- A satellite receiver for SOI Asia network
  - Input radio carrier from satellite UDL on Coax. Interface
  - Output Ethernet frames from LAN Interface
  - Provide Receiver functions of UDLR
    - GRE encapsulation
    - DTCP client
  - UDBox, SONY-BOX

98

### Receive Router

- PC-based router for Unicast / Multicast routing
- Relationship with Satellite Receiver
  - Forward packet from Receive-only network to UDL (Satellite Receiver)
  - Forward GRE packets from Satellite Receiver to BDL (LAN connection to the Internet)

99

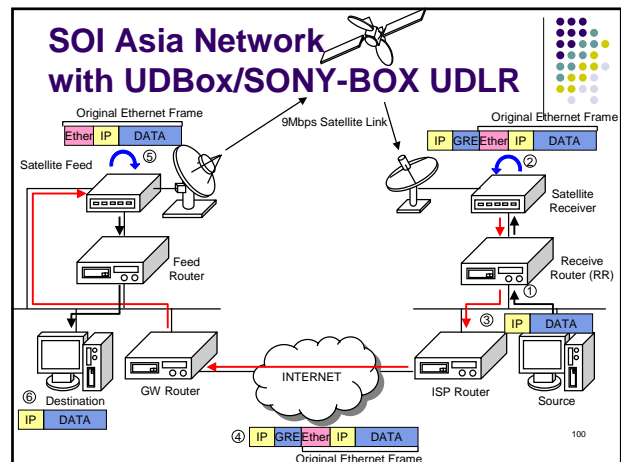

100

### Requirements for Developing SOI-Asia Network

101

### Connecting Devices

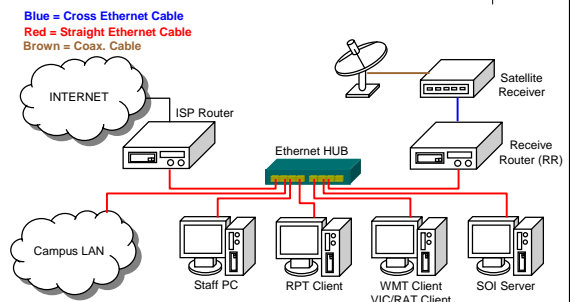

102

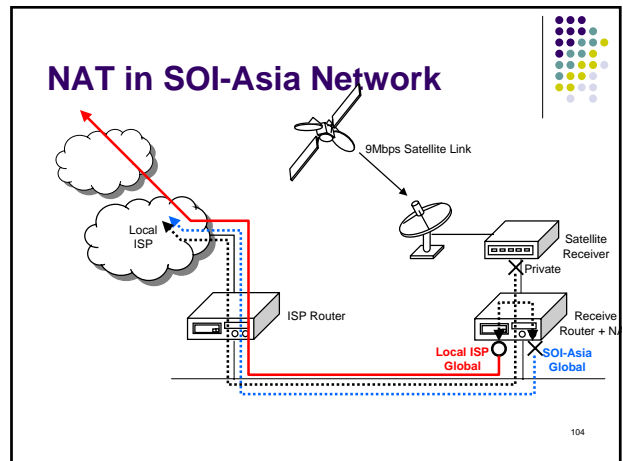
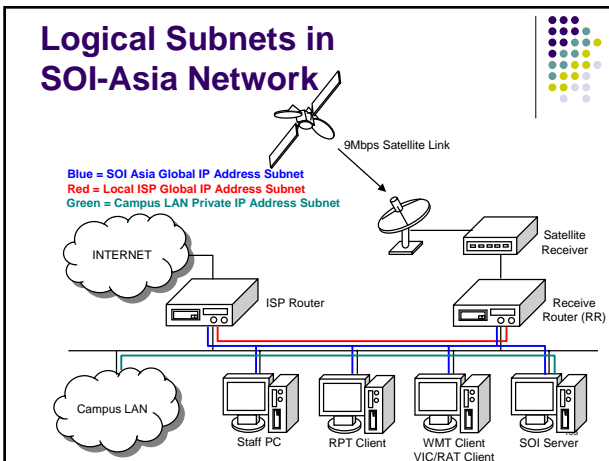

## Receive Router Configuration

- ### SOI-Asia Network Routing Configuration Outline
- Routing in the SOI-Asia Network
    - Unicast IPv4 ··· Static Routing
    - Unicast IPv6 ··· **Dynamic** Routing using OSPF
    - Multicast IPv6 ··· Dynamic Routing using PIM-SM
  - Unicast IPv4
    - sfc-udl-feed advertises each route to each partner site

- ### Steps to Install Receive Router
- Kernel Configuration
  - IPv4 Address Configuration
  - Unicast Routing
  - NAT Configuration
  - IPv6 Address Configuration
  - Unicast Routing
  - Multicast Routing

## IPv4 Private Addressing for Receive Router and Satellite Receiver

## Old configuration

- Many RO sites use private IP address for the subnet where UDLR box and RR connect.
- According to our site setup manual
  - UDLR box should use 192.168.0.1
  - RR should use 192.168.0.2



109

## Problem on current configuration

- RR detects MAC addresses of UDLR boxes, which are not located in the local site.

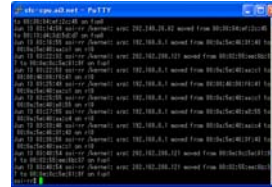

- Connectivity fluctuates if wrong MAC address is learned on UDLR box and RR



110

## Direction

- For the RO sites using private IP address for UDLR box and RR
- Make UDLR boxes and RRs be unique



111

## Operation

- Network part of private IP address
  - Apply the fourth octet of the assigned global IP address to the third octet of the private network address
- Host part of private IP address
  - Give 1 to UDLR box as host address
  - Give 2 to RR as host address
- In the case that RR should use 202.249.25.194 as its global IP address
  - UDLR box should use 192.168.194.1
  - RR should use 192.168.194.2



112

## Configuring RR

Achmad Husni Thamrin  
SOI Asia Global-e-Workshop

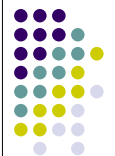

114



113

## Logical Subnets in SOI Asia RO Network

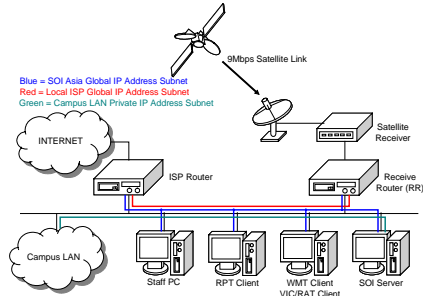

115

## NAT in SOI Asia RO Network

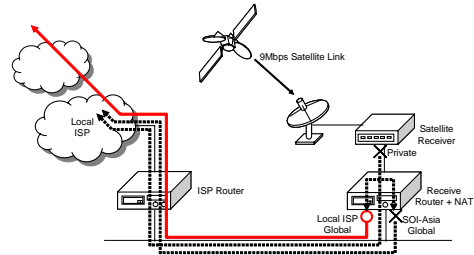

116

## Steps

- Compile kernel to enable Multicast Routing and NAT
- Configure IPv4 network
- Configure IPv6 network
- Confirm reachability to SFC UDL Feed Router
- Configure OSPFv3 using Zebra
- Configure PIM-SMv6

117

## Lab Work 8.1 Kernel Installation

Page 11

118

## Lab Work 8.2 Network Configuration

Page 12

119

## Lab Work 8.3 Verify Connectivity

Page 13

120

## Lab Work 8.4 Configure IPv6 unicast routing

Page 14



121

## Lab Work 8.5 Configure PIM- SMv6

Page 15



122

## Lab Work 8.6 Final Check

Page 16



123