

SOI Asia Classroom Environment

SOI Asia realtime lecture is an interactive remote learning environment which enables distant lecturer and many groups of students to participate in one virtual classroom.

This textbook will guide SOI Asia operators to setup and prepare SOI Asia realtime lecture. This textbook contains following topics.

1. SOI Asia network review
2. SOI Asia lecture overview
3. Hardware and Software preparation
4. SOI Asia realtime lecture
 - Receiving lecture stream
 - Synchronized Presentation
 - Realtime Q/A system
 - Staff communication

1. SOI Asia Network Review

SOI Asia is using UniDirectional Link Routing (UDLR) technology, and the packet flow is unique. Each packet flow is described in the following section.

- Unicast Packet flow from SFC to the partner site (Figure 1)
 - 1) Unicast packet generated in SFC
 - 2) Packet is routed to FEED ROUTER
 - 3) FEED ROUTER forwards the packet to SONY FEED
 - 4) SONY FEED changes Ethernet packet to satellite signal, and forwards the signal to satellite
 - 5) Partner site antenna receives the packet from the satellite and forwards it to SONY BOX.
 - 6) SONY BOX changes the satellite signal to Ethernet packet and forwards it to Receive Router
 - 7) The Receive Router routes the packet to the destination.

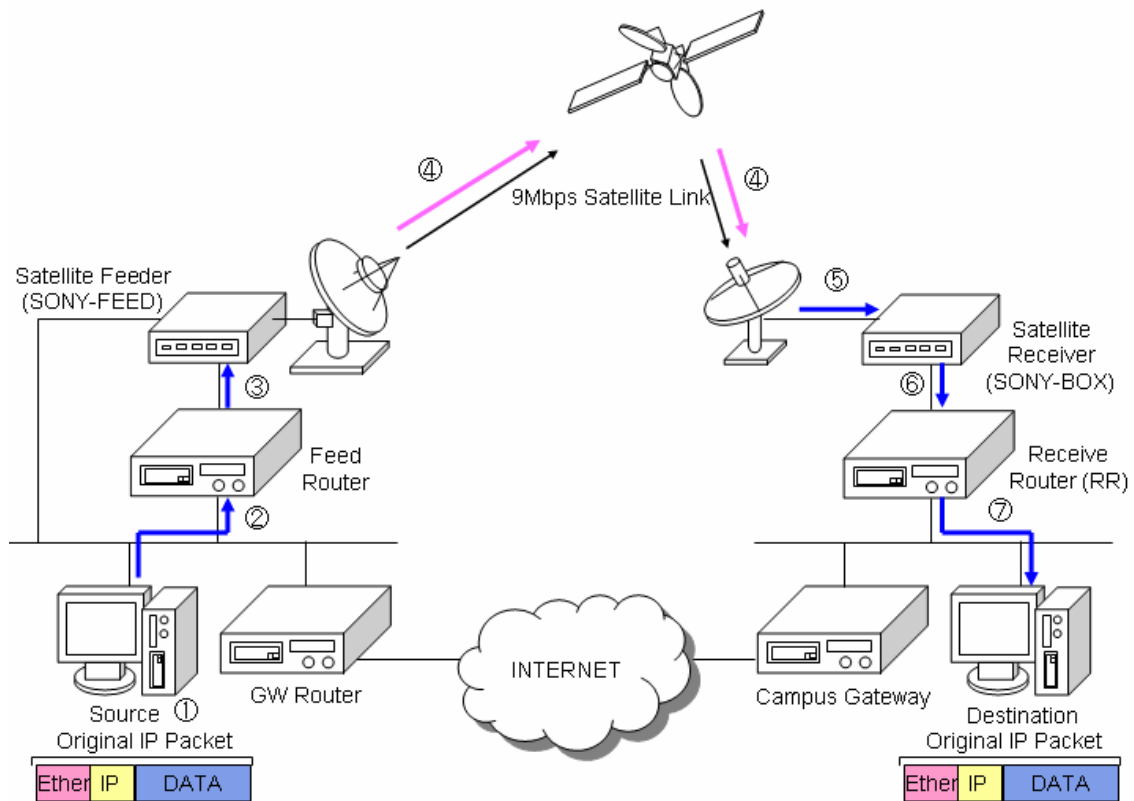

Figure 1. Unicast packet flow from SFC to the partner site

- Unicast packet flow from the partner site to SFC
 - 1) Unicast packet is generated at the partner site, and the source machine sends the packet to the Receive router.
 - 2) The receive router forwards the packet to its default gate, sfc-udl-feed
 - 3) The SONY BOX grabs the packet, and encapsulates the packet to GRE tunneling packet, and adds the destination address of 202.249.25.236, the SONY FEED, and sends it back to Receive Router.
 - 4) The Receive Router have a static route to route packets with destination for SONY FEED to campus gateway, so it sends packets to the campus gateway.
 - 5) The GRE packets are routed in the Internet, and be sent to the SONY FEED.
 - 6) The SONY FEED decapsulates the GRE packet to Ethernet packet, and sends the packet to FEED ROUTER as if it was sent from satellite link.
 - 7) The FEED ROUTER sends the packet to its original destination.

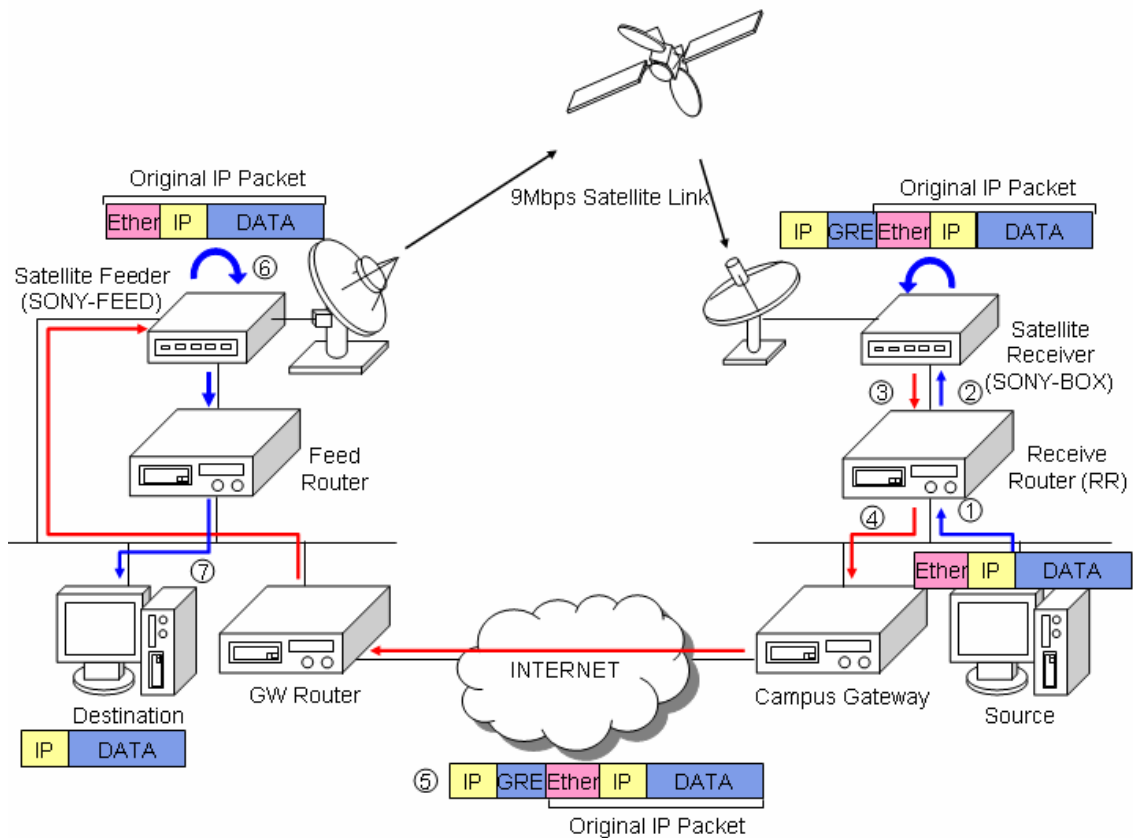

Figure 2. Unicast packet flow from the partner site to SFC

- Multicast packet flow from SFC to the partner site
 - 1) Multicast packet is generated at SFC
 - 2) The packet is forwarded to FEED ROUTER
 - 3) Since SFC site Receive Router is always listening to the multicast, so FEED ROUTER sends the multicast packet to the SONY FEED
 - 4) The SONY FEED transforms Ethernet packet to satellite signal and sends the signal to the satellite
 - 5) The satellite antenna in partners site gets the satellite packet and re-transform it to multicast Ethernet packet, and forwards the data to the SONY BOX.
 - 6) The SONY BOX forwards the multicast packet to Receive Router.
 - 7) The multicast packet is forwarded to the destination by Receive Router

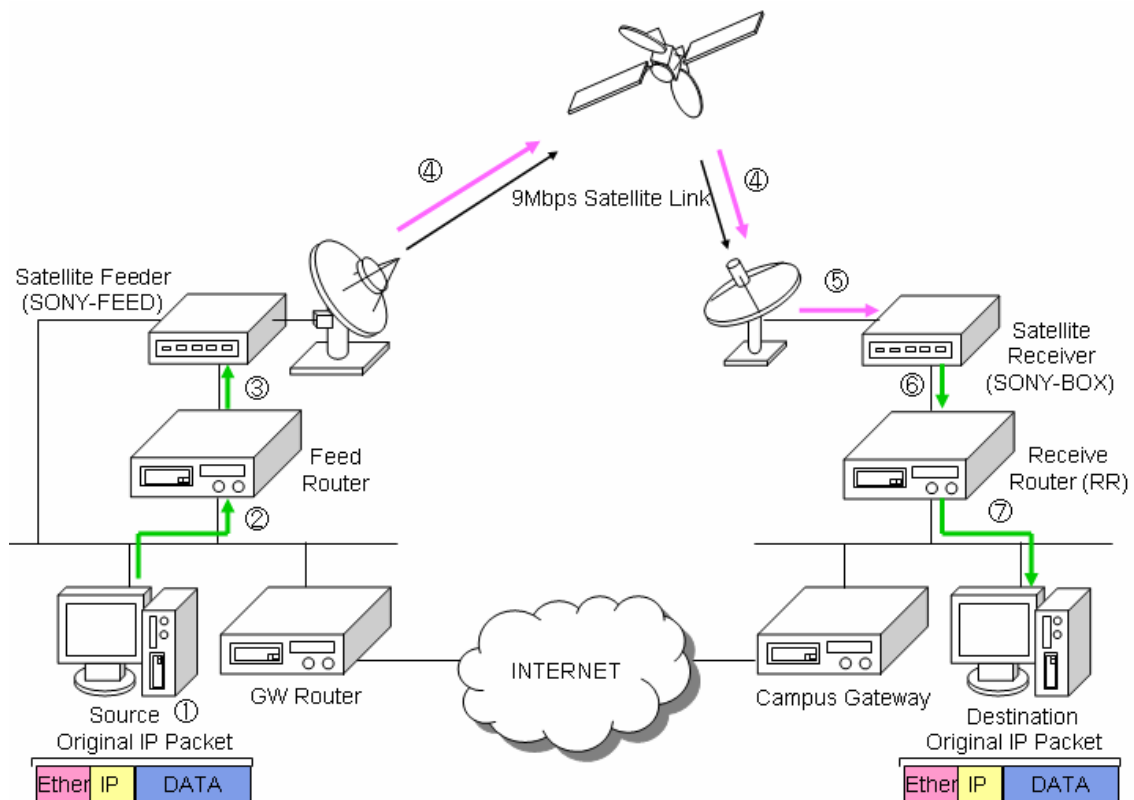

Figure 3. Multicast packet flow from SFC to the partner site

Since Windows Media Player does not require return path for sending the stream, partner sites without any Internet connection can still receive the lecture stream using this scheme.

- Multicast packet flow from partner site to SFC
 - 1) The multicast packet is generated at the partner site and forwarded to its default route, to the Receive Router
 - 2) The Receive Router sends the packet to its default route, sfc-udl-feed
 - 3) The SONY BOX grabs the packet, and encapsulates the multicast packet to GRE packet, adds the destination for SONY FEED, and sends it back to the Receive Router.
 - 4) The Receive Router has a static route to route packets with destination for SONY FEED to campus gateway, so it sends packets to the campus gateway.
 - 5) The GRE packets are routed in the Internet, and be sent to the SONY FEED.
 - 6) The SONY FEED decapsulates the GRE packet to multicast Ethernet packet, and sends the packet both to the satellite and FEED ROUTER.
 - 7) Since there is a listener in the SFC site, the FEED ROUTER sends the packet to the PC in SFC.

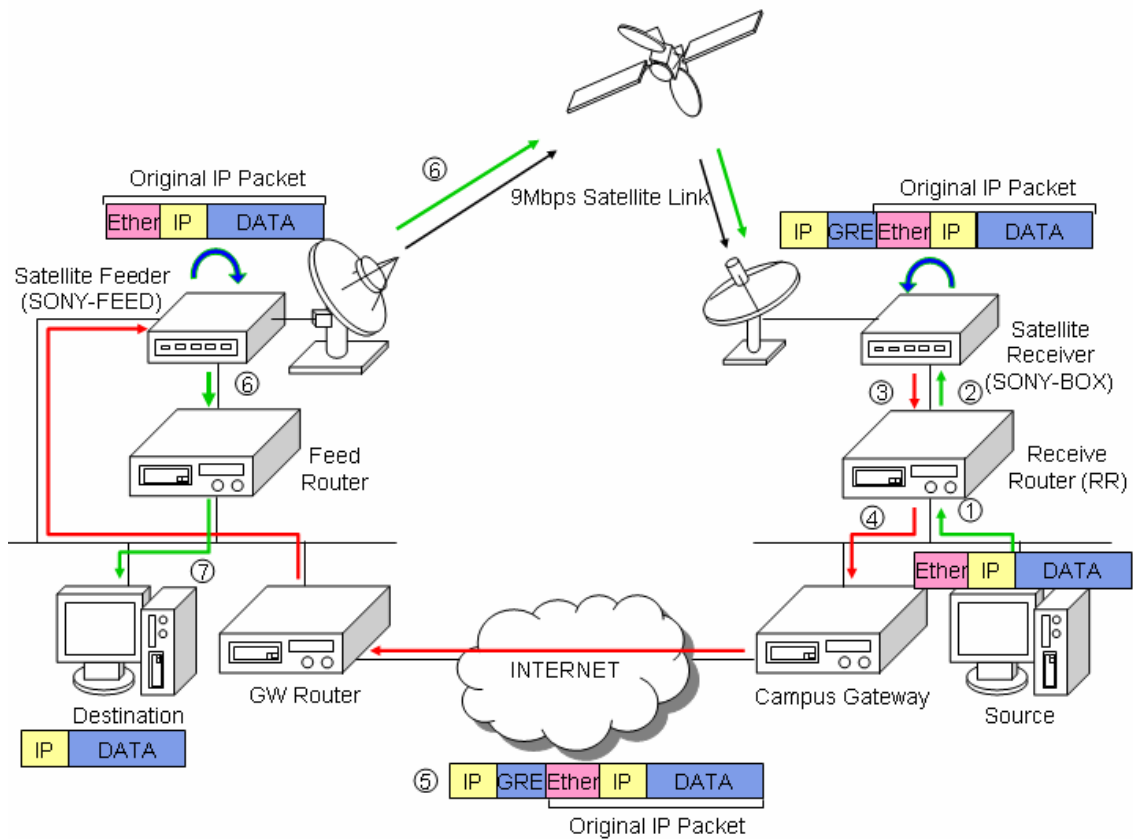

Figure 4. Multicast packet flow from partner site to SFC

Even though multicast packets are hard to be routed because few vendors implement the multicast routing facility to their product, we can route all packets because we encapsulate the multicast packets to GRE tunnel packets. The VIC and RAT stream from the partner site is sent using this scheme.

The SOI Asia configuration is separated into three sites, namely, Lecture site, Gateway site, and the student site as shown in Fig. 3. The lecturer site and the gateway site are connected by more than 2Mbps Internet connection, and interact through DVTS or Polycom. In Gateway site, the video and audio are translated into VIC/RAT and Windows Media format, and delivered to student sites. Student site give feedbacks directly through BBS or IRC to the lecturer site, or using VIC/RAT. As written before, VIC/RAT streams are delivered to gateway site once, and delivered to every student site.

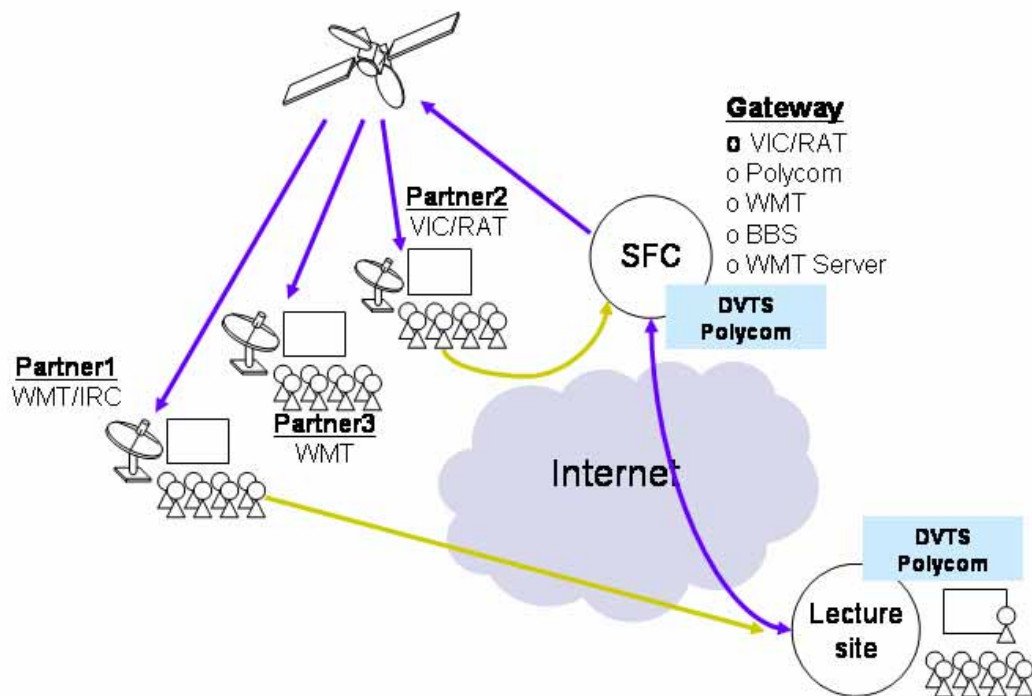

Figure 5. SOI Asia network overview

2. SOI Asia Lecture overview

Typically the SOI Asia realtime lecture is divided into two sessions, lecture session and Q/A session. During the lecture session, students view the realtime lecture video through Windows Media Player together with a synchronized lecture presentation using RPT as shown in Fig. 4. During the Q/A session, SOI Asia operator changes the application to VIC/RAT, and lecturers and students are able to interactively discuss questions and some points related to the topic. In addition, there is a Bulletin Board System (BBS) on the Web page so that students can post questions during and after the classroom.



Fig. 4 Realtime classroom

All activities taking place in local classroom are undertaken by SOI Asia operators. An operator has to setup and test hardware, software, audio, video before the lecture begins first locally, and then with Japan site. During the lecture, operator communicates with other sites especially Japan site to coordinate the event, to report the current status of lecture and to troubleshoot problems that might unintentionally occurs. When there are many sites joining the lecture, Japan staff will coordinate to decide the order of raising questions on Internet Relay Chat (IRC).

3. Hardware and Software preparations

3.1 Specs for Hardware and Software

Hardware and software needed for SOI Asia realtime classroom are listed in table 1 and 2 respectively. Software is available at the specified sources. The setup instructions in following sections describe when and where you will install these software.

Table 1. Hardware for SOI Asia Standard Network

Hardware	Amount	Specification
PC < stream sending/receiving>	1	<ul style="list-style-type: none"> - Windows OS (98/ME/2000/NT/XP) - Pentium III 800MHz for CPU - 256M memory - 8G or larger HDD - Sound card (any sound card listed in http://www-mice.cs.ucl.ac.uk/multimedia/software/rat/faq.html#pccards is fine) - Video card (Ospray is recommended) - One Ethernet network card
PC < PowerPoint Synchronization>	1	<ul style="list-style-type: none"> - Windows 2000 + Microsoft PowerPoint 2000 - Pentium II 400 or higher - 64M memory - 2G HDD - One Ethernet network card
PC <staff communication>	1	<ul style="list-style-type: none"> - Pentium II 400 or higher - 64M memory - 2G HDD - One Ethernet network card
Projector	2	
Video camera	1	<ul style="list-style-type: none"> - Digital video, 8mm or VHS <SOI group uses SONY: DCR-TRV900>
Video/Audio Cables	2	<ul style="list-style-type: none"> - One Video cable to connect video camera and PC - One Audio cable to connect video camera and PC
Speaker	1	
Echo Canceller	1	DSP1124P
Audio Mixer	1	MX1604
Power Amp	1	AMERICAN_AUDIO V1500
Microphone	2	
Surge Protector	4	
Power Transformer	2	

Table 2. Software for SOI Asia Standard Network

Software	Purpose	Source
Window Media Player	Receiving lecture stream	http://www.microsoft.com/windows/windowsmedia/download/default.asp
VIC/RAT	Send/Receive stream	http://www.soi.wide.ad.jp/project/soi-asia/manual/vic-rat/vic-2.8ucl-1.1.3-win32.exe http://www.soi.wide.ad.jp/project/soi-asia/manual/vic-rat/rat-4.2.20-win32.exe

3.2. Hardware setup

The simplest configuration for VIC/RAT is just to connect camera, a microphone and a speaker directly to the VIC/RAT machine. However, since we get much echo using the VIC/RAT, and the audio volume is not in constant level at each site, SOI Asia recommend to use mixer, echo canceller, and amplifier.

Fig. 5 shows the configuration of SOI Asia standard classroom configuration.

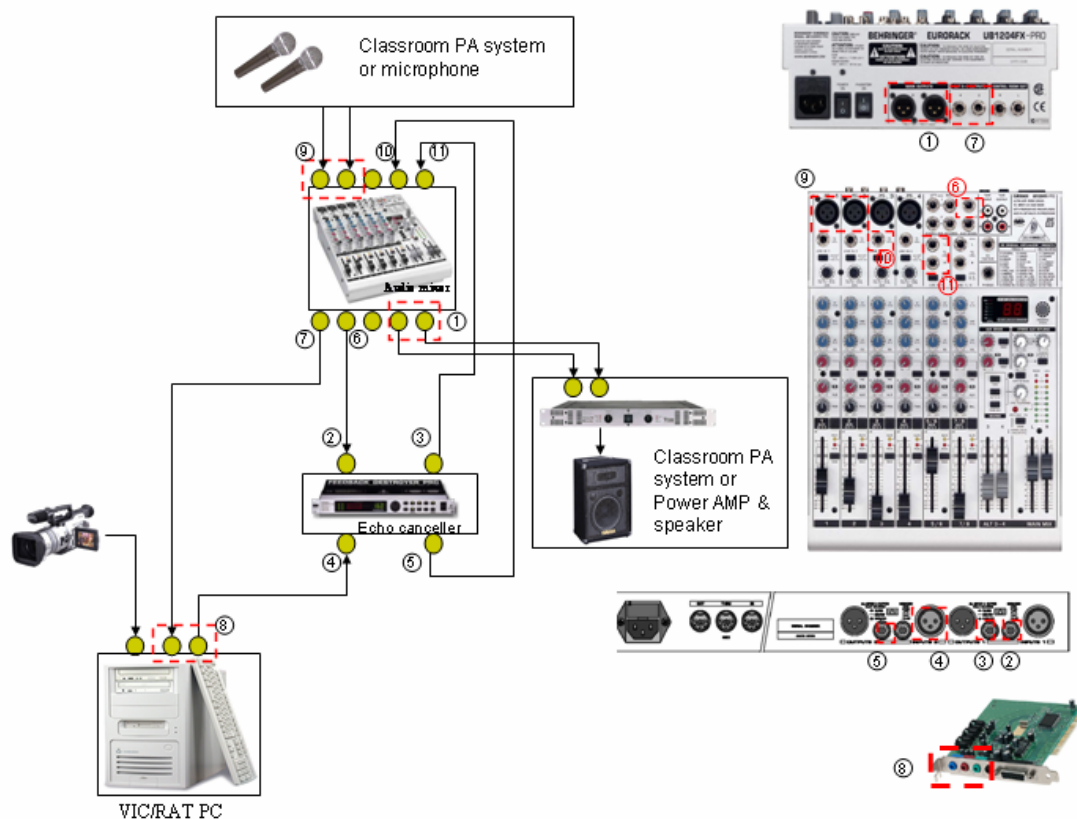

Fig. 5 Video/Audio Setting for VIC/RAT

4. SOI Asia realtime lecture applications

4.1. Receiving lecture stream

To receive lecture stream, a receiving program must be installed to a PC which screen will be displayed to the class by projector. There are two applications for receiving lecture streams, Windows Media Player and VIC/RAT. SOI Asia recommends Windows Media Player for the standard configuration because VIC/RAT requires return path, and when packet loss occurs, VIC/RAT losses packets. This makes video and audio un-smooth.

To use the Windows Media Player, please download the program first from the following URL and install to the PC.

<http://www.microsoft.com/windows/windowsmedia/download/default.asp>

After the installation, download .asx and .nsc files from the following URL to the same directory on the PC.

<http://www.soi.wide.ad.jp/soi-asia/wmt/>

Click the .asx file, and the Windows Medis Player will launch to receive a lecture stream

4.2. Synchronized Presentation

In SOI Asia lecture environment, a PowerPoint presentation is displayed together with the lecture video stream. The slide changing is not statically controlled by SOI operator but is done automatically through a system called RPT. RPT synchronizes the slide changing on the lecturer's laptop with those on partners' machine.

- a) Download RPT program from the following URL to a PC, which the PowerPoint presentation will be displayed to the class by another projector.

<http://www.soi.wide.ad.jp/soibean/index-e.html>

- b) Unzip the file and put *RPTHook.dll* to the following directories.

Windows95, 98, 2000: "C:\WINDOWS\system32"

WindowsXP: "C:\WINDOWS\system32"

- c) Get a Power Point file of the lecturer from SOI Asia website.

<http://www.soi.wide.ad.jp/soi-asia/staff/>

- d) Open the Power Point file, and start RPT by clicking RPT.exe.

It is important in window 95 to start powerpoint before RPT, else there will be an error.

- e) You will get a pop up window "Connect IRC Server", configure as below. Please use IRC channel #soi-rpt for VIC/RAT and #soi-rpt2 for Windows Media Player

Server : irc.kyoto.wide.ad.jp

Port : 6667

Channel : #soi-rpt

Nickname : your name

Password : karaage

** Don't select URL and Send Message

select [connect]

- f) Click PPT Start, it will switch to the PowerPoint window.
- g) Click Start, PowerPoint goes into slide show mode and the slide changes are synchronized with the one in lecturer's machine.

4.3. Realtime Q/A system

In SOI Asia environment, student site chooses the application for interactive Q/A based on their Internet connections. If your Internet connection is good enough to send video and audio (minimum 128kbps), use VIC/RAT, which is a video conferencing tool. This application can both send and receive audio and video stream among many parties.

- a) Download the application and install both of them to PC. The default installation directory is "C:\Program Files\bone".

<http://www.soi.wide.ad.jp/project/soi-asia/manual/vic-rat/vic-2.8ucl-1.1.3-win32.exe>

<http://www.soi.wide.ad.jp/project/soi-asia/manual/vic-rat/rat-4.2.20-win32.exe>

(You may find the details manual of VIC/RAT at

<http://www.soi.wide.ad.jp/project/soi-asia/manual/vic-rat/>)

- b) Start VIC using SOI Asia specific address and port

C:\Program Files\bone>vic.exe 233.18.109.3/6666

- If no one is sending video, you will see a waiting for video message. If there are some sending videos, you should see video/audio of them.
- To send a video stream, click Menu button in VIC program. Click the Device button and choose your video card. Then, enable the transmit checkbox at the upperleft corner to start sending the video. To stop sending a video, click the release button.

- c) Start RAT using SOI ASIA specific address and port

C:\Program Files\bone>rat.exe 233.18.109.4/7777

- Go to option -> audio category and Make Silence Supression OFF
- To start send an audio stream, check the Talk button in the RAT main window.

4.4 Staff Communication

In SOI Asia realtime classroom, staff communication is needed to know each site's status, and decide the order in Q/A session. The main communication channel is Internet Relay Chat (IRC). The alternatives are MSN messenger and Yahoo messenger, but these applications are not recommended, because these applications send messages only to specific person.

- a) Internet Relay Chat (IRC)

Please install IRC clients first in your PC. Any IRC client is fine. JP staff are using below applications:

CHOCOA: <http://www.labs.fujitsu.com/en/freesoft/chocoa/index.html>

mIRC: <http://www.mirc.com/index.html>

For configurations, please input following information.

Server: irc.kyoto.wide.ad.jp

Port: 6667

Password: karaage

Channel: #soi-asia

b) MSN messenger

Download and install the MSN messenger from the following URL.

<http://messenger.msn.com/>

Log in with your .NET passport and let us know your ID.

(JP staff MSN accounts)

Talk for	NAME	ACCOUNTS
Lecture Info.	Keiko Okawa	russianblueao@hotmail.com
	Shoko Mikawa	funyafunya@hotmail.com
	Noriatsu Kudo	n_kudo@hotmail.com
Network	Kotaro Kataoka	kotaro_away@hotmail.com
	Achmad Husni Thamrin	dukeoc01@hotmail.com

c) Yahoo messenger

Download and install the Yahoo messenger form the following URL.

<http://messenger.yahoo.com/>

Log in with your Yahoo account, and let us know your ID.

(JP staff Yahoo accounts)

Talk for	NAME	ACCOUNTS
Lecture Info.	Shoko Mikawa	shoko_mikawa2002
Network	Achmad Husni Thamrin	dukeoc01